



FOOD-PROCESSOR K-82

Bowl capacity: 8 l. 2-speed.



ACCESSORIES

- Blades for CK / K / KE
- "Cut&mix" scrapers CK / K / KE

SPECIFICATIONS

Bowl capacity: 8 l
 Bowl dimensions: Ø240 mm x 199 mm
 Total loading: 900 - 1500 W
 Speed, min-max: 1500 rpm / 3000 rpm

External dimensions (W x D x H)

- ✓ Width: 286 mm
- ✓ Depth: 387 mm
- ✓ Height: 473 mm
- Net weight: 22.6 kg
- Crated dimensions
440 x 355 x 570 mm
- Volume Packed: 0.09 m³
- Gross weight: 25.6 kg

AVAILABLE MODELS

1050850	Cutter K-82 400/50/3
---------	----------------------

* Ask for special versions availability

SALES DESCRIPTION

ACTIVE Heavy Duty line. 2-speed motor block + 8 l cutter bowl with toothed blades.

Efficiency and performance

- ✓ Professional performance: large capacity.
- ✓ 2-speed.
- ✓ Top orifice in lid, to add liquids while the machine is in operation.
- ✓ "Cut&mix" mixer optional.

Built to last

- ✓ Robust construction of stainless steel and food-grade materials of the highest quality: stainless steel motor block with aluminium lid.
- ✓ Stainless steel bowl with highly-resistant lid.

Maximum comfort for the user

- ✓ Waterproof control panel that is very intuitive to use.

Maintenance, safety, hygiene

- ✓ Safety microswitches on the hopper and lid position.
- ✓ Appliance certified by NSF International (regulations on hygiene, cleaning and materials suitable for contact with foods).
- ✓ 100% tested.

INCLUDES

- ✓ Set of serrated blades.

OPTIONAL

- "Cut&mix" scraper.
- Perforated blades.
- Smooth blades.

DYNAMIC PREPARATION
CUTTER-MIXERS & EMULSIFIERS



product sheet
updated 09/01/2025



FOOD-PROCESSOR K-82

Bowl capacity: 8 l. 2-speed.



DYNAMIC PREPARATION
CUTTER-MIXERS & EMULSIFIERS

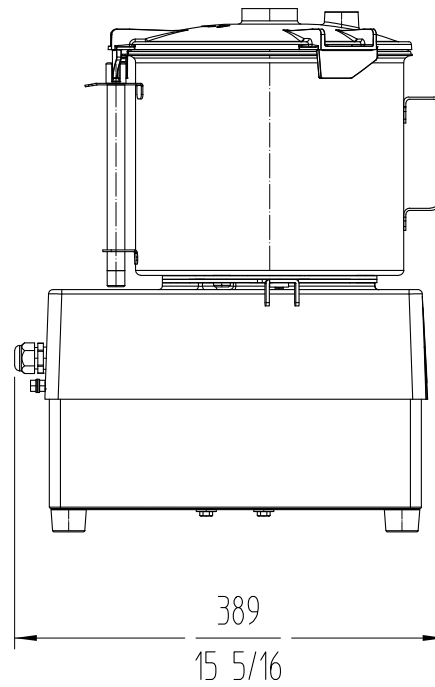
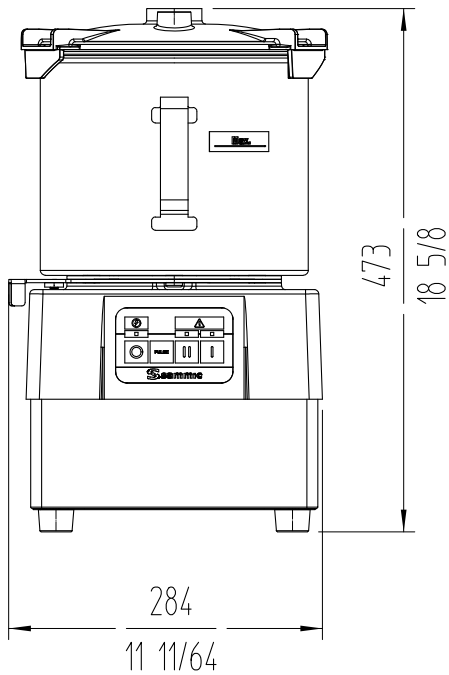

 **sammic** | www.sammic.com
Food Service Equipment Manufacturer

Polígono Basarte, 1. phone +34 943 15 72 36
20720 Azkoitia, Spain sales@sammic.com



Project	Date
Item	Qty
Approved	

product sheet
updated 09/01/2025