



VACUUM SEALER SE-316

Tabletop model. 665 cf/h. 12.6"



SALES DESCRIPTION

12.6" sealing bar.
665 cf/h Busch vacuum pump.
Vacuum controlled by sensor.

- ✓ Powered by Busch.
- ✓ Vacuum controlled by sensor.
- ✓ Vacuum PLUS.
- ✓ Digital keyboard.
- ✓ Control panel equipped with display indicating the exact vacuum percentage.
- ✓ "Pause" button to marinate food.
- ✓ Safe liquid packing thanks to sensor control.
- ✓ Double seal.
- ✓ Cordless sealing bar.
- ✓ Bag-sealing programme.
- ✓ Pulse-controlled decompression.
- ✓ Vac-Norm ready with Automatic decompression.
- ✓ Stainless steel body and chamber. Deep-drawn chamber.
- ✓ Damped transparent lid.
- ✓ Dry-oil programme for drying the pump.
- ✓ Working hours counter for oil changes.
- ✓ Safety system with protection against vacuum failure.
- ✓ NSF-listed model.

INCLUDES

- ✓ Sensor controls
- ✓ Up to 10 seconds of extra vacuum pull
- ✓ Soft air function
- ✓ Dry oil cycle
- ✓ BUSCH pump
- ✓ NSF approved
- ✓ Clear methacrylate lid
- ✓ Filling plate

OPTIONAL

- Vacuum packing bags series
- External vacuum kit for Vac-Norm, containers and accessories
- Support for liquid packaging
- Additional filling plates

ACCESSORIES

- Filling plates
- Liquid insert plates
- Vac-norm external vacuum kits
- Vac-norm containers
- Smooth bags for vacuum packing

SPECIFICATIONS

Pump capacity: 665 cf/h
 Bar length: 12.6"
 Total loading: 0.5 Hp
 Vacuum pressure (maximum): 2 mbar

Internal dimensions

- ✓ Width: 13"
- ✓ Depth: 14"
- ✓ Height: 6.1"

External dimensions (W x D x H)

- ✓ Width: 15"
- ✓ Depth: 18.3"
- ✓ Height: 16"

Net weight: 93.3 lb

Noise level (1m.): 75 dB(A)
 Background noise: 32 dB(A)

AVAILABLE MODELS

1140630 SE-316 230/50-60/1

1140631 SE-316 120/50-60/1

* Ask for special versions availability

FOOD PRESERVATION AND SOUS-VIDE
VACUUM PACKING MACHINES • SENSOR LINE



product sheet
updated 05/13/24



VACUUM SEALER SE-316

Tabletop model. 665 cf/h. 12.6"



FOOD PRESERVATION AND SOUS-VIDE
VACUUM PACKING MACHINES • SENSOR LINE

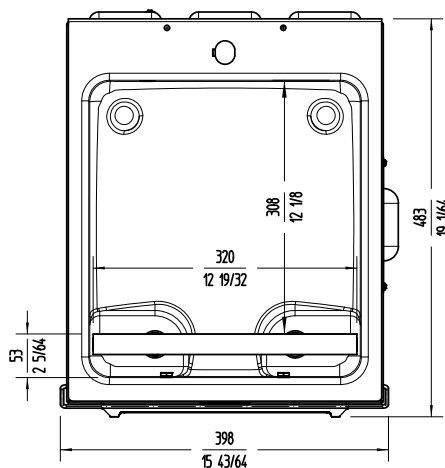
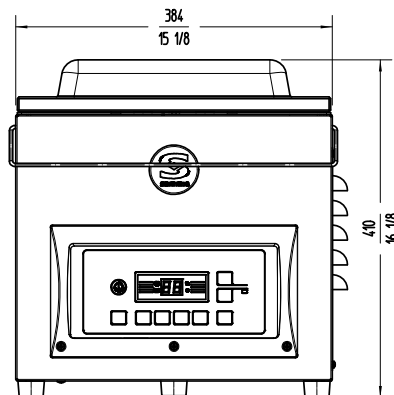
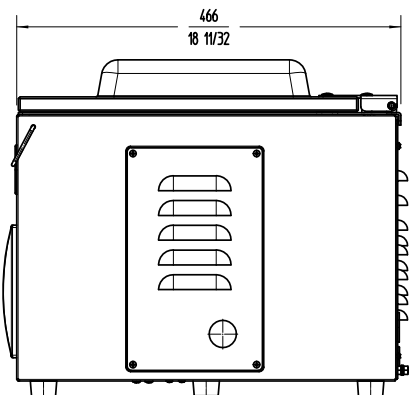

sammic | www.sammic.us
Food Service Equipment Manufacturer

usa@sammic.com
1225 Hartrey Avenue
60202-1056 Evanston, IL

phone +1 (224) 307-2232
toll free +1 844 275 3848



Project	Date
Item	Qty
Approved	

product sheet
updated 05/13/24