



VACUUM SEALER SU-316GP+

Tabletop model. 670 cf/h. 12.6”.



SALES DESCRIPTION

12.6” sealing bar.
670 cf/h Busch vacuum pump.
Vacuum controlled by sensor.

- ✓ Powered by Busch.
- ✓ Vacuum controlled by sensor.
- ✓ Vacuum PLUS.
- ✓ LCD colour screen: all information at a glance.
- ✓ Backlit touch keyboard.
- ✓ Programmable: 99-programme memory. Blocking option.
- ✓ “Pause” button to marinate food.
- ✓ Phased vacuum programme.
- ✓ Detection of the evaporation of liquids.
- ✓ Double seal.
- ✓ Cordless sealing bar.
- ✓ Bag sealing program.
- ✓ Progressive decompression.
- ✓ Vac-Norm ready with automatic decompression.
- ✓ Stainless steel body and chamber. Deep-drawn chamber.
- ✓ Damped transparent lid.
- ✓ Dry-oil programme for drying the pump.
- ✓ Working hours counter for oil changes.
- ✓ Safety system with protection against vacuum failure.
- ✓ NSF-listed model.

INCLUDES

- ✓ Bluetooth connectivity and connection for printer (P models).
- ✓ PLUS welding for retort pouches (+ models).
- ✓ Inert gas flush (G models).
- ✓ BUSCH pump.
- ✓ Sensor Controls.
- ✓ 25 programmable settings.
- ✓ Vacuum PLUS: up to 10 seconds of extra vacuum pull.
- ✓ Soft air function.
- ✓ Clear methacrylate lid.
- ✓ “PAUSE” function.
- ✓ Liquid detection system.
- ✓ Dry oil cycle.
- ✓ NSF Approved.
- ✓ Filling plate.

OPTIONAL

- Printer series
- Vacuum packing bags
- External vacuum kit for Vac-Norm, containers and accessories
- Bag cutting kit
- Support for liquid packaging
- Additional filling plates

ACCESSORIES

- Filling plates machines
- Liquid insert plates
- Vac-norm external vacuum kit
- Vac-norm containers
- Smooth bags for vacuum packing
- Trolley for vacuum packing
- Thermal labels for CG2 / RB printer
- RB desktop printer for SU vacuum packing machines
- Thermal transfer labels for RB printer

SPECIFICATIONS

Pump capacity: 670 cf/h
Bar length: 12.6”

Vacuum pressure (maximum): 2 mbar

Internal dimensions

- ✓ Width: 13”
- ✓ Depth: 14.2”
- ✓ Height: 6.1”

External dimensions (W x D x H)

- ✓ Width: 15”
- ✓ Depth: 18.3”
- ✓ Height: 16”

Noise level (1m.): 75 dB(A)
Background noise: 32 dB(A)

AVAILABLE MODELS

1140755 SU-316P+ 120/50-60/1

1140758 SU-316GP+ 120/50-60/1

* Ask for special versions availability

FOOD PRESERVATION AND SOUS-VIDE
COMMERCIAL VACUUM PACKING MACHINES

product sheet
updated 10/28/24





VACUUM SEALER SU-316GP+

Tabletop model. 670 cf/h. 12.6".



FOOD PRESERVATION AND SOUS-VIDE
COMMERCIAL VACUUM PACKING MACHINES

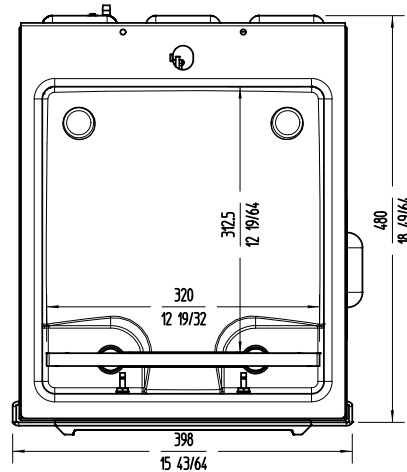
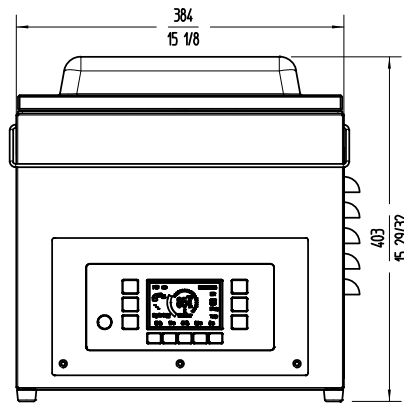
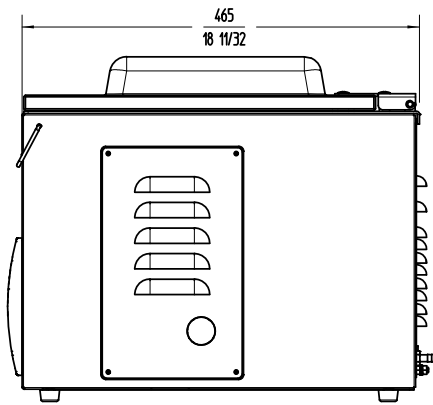

sammic | www.sammic.us
Food Service Equipment Manufacturer

usa@sammic.com
1225 Hartrey Avenue
60202-1056 Evanston, IL

phone +1 (224) 307-2232
toll free +1 844 275 3848



Project	Date
Item	Qty
Approved	

product sheet
updated 10/28/24