



PASS-THROUGH WAREWASHER UX-100 DD

Pass-through glass- and dishwasher. Rack size 500x500mm and door clearance 430 mm.



WARE WASHING
PASS-THROUGH WAREWASHERS



- ✓ Soft start: progressive start-up of the washing pump to protect fragile items.
- ✓ Colour LCD Display: intuitive communication of the machine status by means of messages, colour codes and icons.
- ✓ Dedicated cycles: selection of the ideal washing programme using icons.
- ✓ Adaptable: allows the main parameters of the machine to be adjusted to the needs of each user.
- ✓ TEMPERATURE DISPLAY
- ✓ Wash Plus+ function: increases the intensity of the wash cycle for greater cleaning performance
- ✓ Control panel with IP65 humidity protection.

You will never WASH ALONE

- ✓ Tech-Services: our team of technicians will help you so that your machine is always ready for use.
 - ✓ Design Services: tell us what your needs are and we will advise you.
 - ✓ 60 years of experience and know-how at your disposal.
- Detergent Dispenser 1 glasses basket. 1 mixed basket (plates). 1 cutlery basket.

INCLUDES

- ✓ Detergent dispenser..
- ✓ Rinse aid pump.
- ✓ 1 glasses basket.
- ✓ 1 mixed basket (plates).
- ✓ 1 cutlery basket.

OPTIONAL

- Drainage pump with level sensor. Proactive tank water renewal.

ACCESSORIES

- Tables for pass-through dishwashers
- Manual water softeners
- Automatic water softeners
- 500 x 500 mm baskets
- Inserts & supplements
- Central sorting tables
- Double connection central sorting table
- Prewashing tables for pass-through and rack conveyor dishwashers
- Connecting tables for pass-through dishwashers and rack conveyors
- Reverse osmosis devices OS-140
- Dosing equipments for AX / UX hood-type dishwashers

SPECIFICATIONS

Basket dimensions: 500 mm x 500 mm
Useful height: 430 mm

Cycles: 6
Cycle duration: 60/90/100/150/210"
Production baskets / hour: 60/40/36/24/17

Boiler capacity: 8 l
Wash tank capacity: 25 l

Consumption and savings

- ✓ Water consumption/cycle: 3 l
- ✓ Automatic saving mode in: 25'
- ✓ Automatic switch-off: 120'

Loading

- ✓ Pump: 750 W / 1 Hp
- ✓ Boiler: 7500 W
- ✓ Total loading: 8250 W

External dimensions (W x D x H)

SALES DESCRIPTION

Sani-Control: guaranteed disinfection
Exclusive Hydroblade™ washing arms: maximum effectiveness.
3-stage filtering system.

Sani-Control guarantee

- ✓ GUARANTEED DISINFECTION in compliance with standard DIN 10534.
- ✓ THERMAL LOCK function: Ensures that rinsing will be carried out at the ideal temperature to disinfect the dishes.

New recessed bodywork

- ✓ Ergonomic design with rounded corners to prevent the accumulation of dirt and facilitate cleaning.
- ✓ Compact tank volume (50% water saving compared to the previous range).

Hydroblade™ washing arms

- ✓ Redesigned nozzles for greater washing performance.
- ✓ The "monoblock" design delivers durability and resistance to impacts.
- ✓ 30% savings in water consumption during rinsing compared to the previous range.

3-stage filter system: surface, tank and extraction

- ✓ Keeps the washing water in optimal conditions to maintain constant washing performance.

Designed to last

- ✓ "Flow" opening mechanism: allows the hood to be raised with less effort
- ✓ High load capacity 43 cm: suitable for GN 1/1 and Euronorm
- ✓ Stainless steel surface filters for greater stability and resistance during intensive use

Premium warewashing



product sheet
updated 20/01/2024



PASS-THROUGH WAREWASHER UX-100 DD

Pass-through glass- and dishwasher. Rack size 500x500mm and door clearance 430 mm.



- ✓ Width: 648 mm (Wide with handle: 725 mm)
- ✓ Depth: 756 mm (Bottom with handle: 835 mm)
- ✓ Height: 2000 mm / 1510 mm

760 x 860 x 1530 mm
Gross weight: 113 kg

Net weight: 102 kg

Wash temperature: 65°C

Rinse temperature: 87°C

Noise level (1m.): <70 dB(A)

AVAILABLE MODELS

1303324 UX-100B 230/50/1 DD

* Ask for special versions availability

Crated dimensions

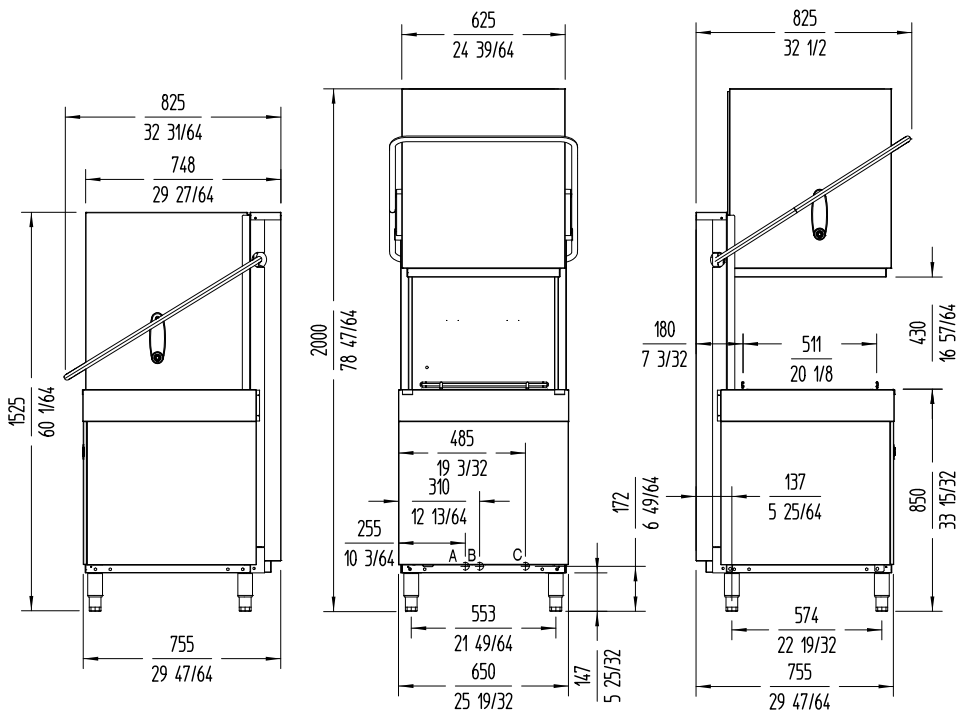

A: Entrada de agua 3/4" GAS.
 B: Tubo de desague Ø30 mm.
 C: Cable conexión.

WARE WASHING
PASS-THROUGH WAREWASHERS



www.sammic.co.uk

Food Service Equipment Manufacturer

Unit 2, Trevanah Road
Troon Industrial Park
LE4 9LS - Leicester

uksales@sammic.com
Tel.: +44 0116 246 1900



Project

Date

Item

Qty

Approved

product sheet
updated 20/01/2024