



POTATO PEELER PI-30

30 kg / 66 lb load per cycle.



DYNAMIC PREPARATION
COMMERCIAL POTATO PEELERS

SALES DESCRIPTION

- ✓ Stainless steel construction commercial potato peeler.
- ✓ Also suitable to peel carrots and other similar products.
- ✓ 0-6 min timer.
- ✓ Removable turntable for easy cleaning.

Robust and efficient construction

- ✓ Construction in stainless steel.
- ✓ Lateral stirrers covered with silicon carbide abrasive (approved by NSF).
- ✓ Aluminium base plate lined with silicon carbide abrasive (approved by NSF), easily removable for cleaning purposes.

User comfort

- ✓ 0-6 min timer.
- ✓ Possibility of continuous operation.

Maximum safety and hygiene

- ✓ Auto-drag of waste to the drain.
- ✓ BPA-free liftable transparent, complete with locking and safety device.
- ✓ Aluminium door with hermetic seal and safety device.
- ✓ Waterproof control board (IP65): Improved reliability against moisture and water splash.
- ✓ Water inlet system with non-return air break.
- ✓ Auxiliary contact for external electric valve.

Energy efficiency

- ✓ Energy efficiency owing to engine optimisation.

OPTIONAL

- Stainless steel floor stand complete with filter with no-foam feature.

ACCESSORIES

- Stands for potato peelers
- Filters for potato peelers M / PI / PES

SPECIFICATIONS

Hourly production: 600 kg / 720 kg
 Capacity per load: 30 kg
 Timer (min-max): 0' - 6'
 Total loading: 730 W

Outlet door dimensions

Door height: 130 mm
 Door width: 160 mm

External dimensions (W x D x H)

- ✓ Width: 622 mm
- ✓ Depth: 760 mm
- ✓ Height: 1002 mm

External dimensions with stand

- ✓ Width with stand: 546 mm
 - ✓ Depth with stand: 760 mm
 - ✓ Height with stand: 1255 mm
- Net weight: 60 kg

AVAILABLE MODELS

1000630 Potato peeler PI-30 230-400/50/3N

1000631 Potato peeler PI-30 230/50/1

1000632 Potato peeler PI-30 220-380/60/3N

1000633 Potato peeler PI-30 220/60/1

1000638 Potato peeler PI-30 120/60/1

* Ask for special versions availability



product sheet
updated 09/01/2025



POTATO PEELER PI-30

30 kg / 66 lb load per cycle.



DYNAMIC PREPARATION
COMMERCIAL POTATO PEELERS

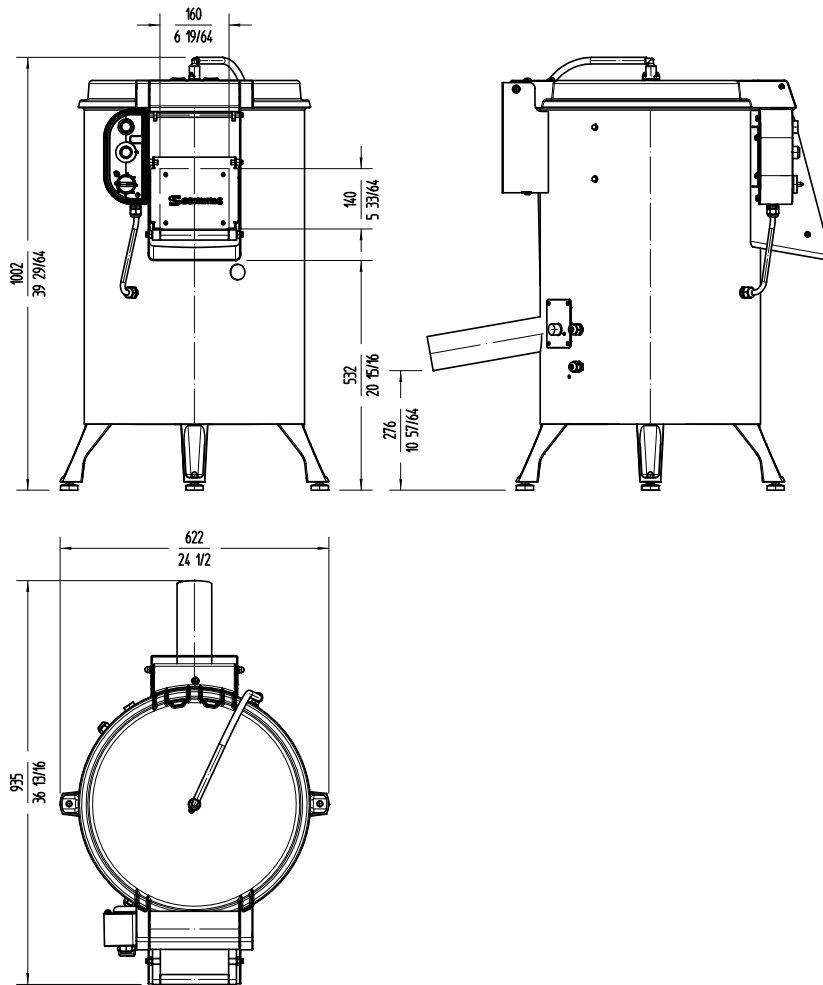

sammic | www.sammic.com
Food Service Equipment Manufacturer

Polígono Basarte, 1. phone +34 943 15 72 36
20720 Azkoitia, Spain sales@sammic.com



Project	Date
Item	Qty
Approved	

product sheet
updated 09/01/2025