

AX-51C AX-100C



Dishwashers ACTIVE-C

User's manual **EN**



ER 0437/1/96



12-21 - 2900457/0



TOC - Contact

[EN] User's manual Active AX-C.....	3
-------------------------------------	---

-EN-

Contact

If you have any queries or problems with the machine, please contact your dealer.



About this manual 3

1 Safety information 3

2 Installation 4

 2.1 Supply scope

 2.2 Prerequisites and preparation for installation

 2.3 Unpacking

 2.4 Assembly

 2.5 Electrical connection

 2.6 First start-up

 2.7 General machine settings

3 Operation 7

 3.1 Preparation for operation

 3.2 Main operating elements

 3.3 Turning the machine on.

 3.4 Main operation

4 Maintenance and troubleshooting 9

 4.1 Safety information

 4.2 Machine maintenance

 4.3 Troubleshooting

 4.4 Spare parts and accessories

5 Disposal 12

6 Technical specifications 12

About this manual

Purpose of the manual

The user manual provides instructions on the safe operation of the *Active AX-C* machine throughout its complete life cycle.

The machine *Active AX-C* has the variants and optional accessories of the AX-51BC/D and AX-100C dishwashers.

Check your model variant and accessory code against the information on the nameplate.

Neutral model variants (without accessories)		
Model	Specifications	Boiler power
AX 51C	Front dishwasher	5.0 kW
AX 100C	Dome-type dishwasher	6.0 kW

Optional accessories

Code	Applies to model variant:		Peristaltic detergent dispenser	Drain pump	Automatic softener	Rinsing constant temperature
	AX 51C	AX 100C				
DD	✓	✓	✓	-	-	✓
BC	✓	✓	-	✓	-	✓
BCD	✓	✓	-	✓	✓	✓

Machine nameplate

- Manufacturer's name and address.
- Machine model and serial number.
- Approval marks.

Declaration of Conformity

The Declaration of Conformity for this machine is included with the warranty cards that forms part of the machine's delivery scope.

Read first, use later

Read this manual before using the machine.

Always keep the manual at hand and in good condition

Store this manual within easy access of machine users and in an area that protects it from rapid deterioration.

Conventions of the manual

- Cross-references to other sections: ►
- Optional functions or elements not included with the main supply: (*)
- Optional features depending on the model: [Model ...]

Trademarks and copyright

- *Sammic* is a registered trademark of *Sammic, S.L.*

1 Safety information

Intended use

The machine has been designed for washing kitchenware and utensils in the hospitality and catering sector, communities and agri-food industry.

Reasonably foreseeable misuse

The use of this machine for degreasing and cleaning machined parts is not permitted. Other professional uses of this machine, such as for healthcare or chemical applications, are not permitted.

Limits of use

The machine must not be used in explosive atmospheres.

User qualifications

Installation qualification

The installation of this machine requires basic notions of plumbing and basic professional training in electricity, electronics or maintenance.

Qualification for operation and periodic maintenance

Operation of this machine requires basic training in the use of this dishwasher.

This machine is not designed for use by people (including children) with reduced physical, sensory or mental capacities or who lack the necessary experience or knowledge unless they have received supervision or instructions regarding the machine's use from a person responsible for their safety.

Qualification for troubleshooting

Troubleshooting for this machine is allowed by *Sammic*-approved service companies and technicians.

Hazards inherent to the product

- **Risk of trapping with the door or dome:**
 - ⇒ When closing the door or dome, be careful not to get your fingers caught in the frame or base.
 - ⇒ [Dome models] When closing or opening the dome, take care that your clothes do not get caught in the moving parts of the lifting mechanism.
- **Risk of slips and falls in the area around the dishwashing machine:** water splashing from the machine is common.
 - ⇒ When walking near the machine, pay attention to the condition of the ground.
- **Airborne noise:**
 - For a standard machine, the noise emitted by the machine is 69 dB(A) (distance 1 m).

Safety warnings in the manual

Warning

“Warning” safety warnings could result in severe, irreversible personal injuries or death.

Caution

“Caution” safety warnings could result in severe, reversible personal injuries.

Other warnings in the manual

Notice

“Notice” warnings could result in damage to the machine.

Information

The tables of “Information” contain advice on how to use the machine correctly and efficiently.

2 Installation

2.1 Supply scope

- Documentation:
 - User manual.
 - Warranty card and Declaration of Conformity.
 - List of spare parts.
 - Electrical circuit diagram.
- Machine
- Power supply cable
- Drain hose

2.2 Prerequisites and preparation for installation

Tools and material required for installation

- Included in the supply:
 - Power supply cable
 - Drain hose
- Not included for mechanical assembly:
 - Flat screwdriver
 - No. 10 box spanner
 - Universal pliers
 - Clamp
 - Pressure gauge
- Not included for electrical assembly:
 - Power strip and/or European plug type “F” or three-phase plug (depending on the installation)
 - Electrical tester

Space required for installation

Information

Figure with machine dimensions: see appendix at the end of the manual.

- Check that the water line is less than 1.50 m from the intended location of the machine.

Electrical connections

Before installation, take note of the power input required by the machine. [▶ 6 *Technical specifications* p. 12].

Fig. 1: Machine connection points

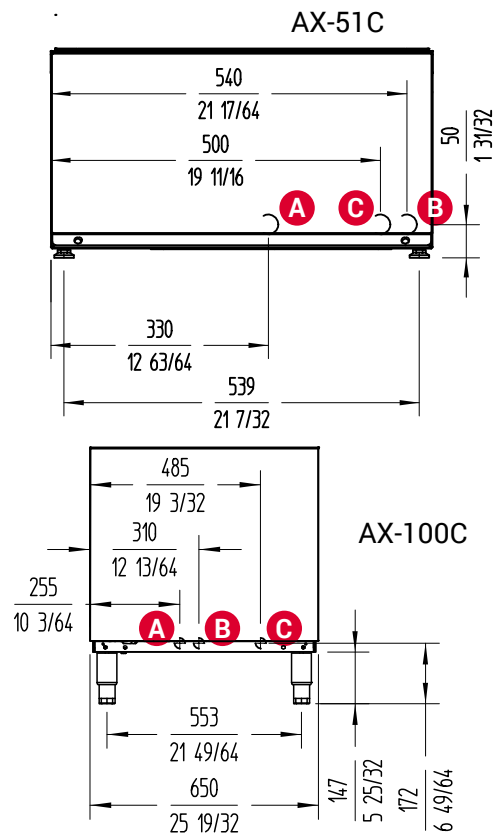

- A Drain pipe \varnothing 30 mm
- B Water inlet $\frac{3}{4}$ " GAS
- C Connection cable



Preparation for installation

- 1) Check that the installation area is flat and stable.
- 2) Check that the water line has a 3/4" GAS shut-off valve at the end closest to the machine.
- 3) Check that the dynamic pressure of the machine feed water is within the following range of values:

Dynamic water pressure	Minimum value	Maximum value
C Models	0.7 bar (70 kPa)	4 bar (400 kPa)

- ⇒ If the water pressure is higher than the maximum indicated, install a pressure regulator to set the pressure between 2.5 and 4 bar (250 and 400 kPa).
 - ⇒ If the water pressure is below the minimum value, install a back-up valve.
- 4) Check the following values of the feed water flow rate:

Water flow rate	Minimum value
C Models	7 L/min

- 5) For the maximum drain height, observe the following values:

Drain height	Maximum value
Models with drain pump (B)	1,000 mm

2.3 Unpacking

Warning

Risk of trapping hands

There is a high risk of trapping your hands if you lift the machine onto the base and place it on the ground.

- To move the machine from one place to another, hold the machine from the sides.

- 1) Remove the packaging that protects the machine.
- 2) Lower the machine from the pallet on which it is mounted.

2.4 Assembly

Warning

Risk of serious accidents if the machine cannot be disconnected or turned off

- When installing the machine, make sure the operator will be able to reach the switch and plug without difficulty.

Notice

Risk of water leakage

- Before installation, turn off the water stopcock.

- 1) Screw the legs to the base of the machine.
- 2) Adjust the height of the legs so that the machine is stable and level with the ground.
- 3) Place the machine at the installation site.
- 4) Check that the tap water pressure is within the parameters specified in the previous chapter (use of the pressure gauge).

Notice

Risk of hose clogging and/or choking

- Avoid making reductions with the hose when installing.

- 5) Connect the water outlet hose to the drain point.
- 6) Connect the water supply hose to the mains water point.

Caution

Risk of irritation due to chemical exchange and foam release

If you insert the detergent and rinse aid inlet hoses into the wrong bottles, the machine will produce excessive foam.

- Pay attention to the labelling on the chemical hoses before inserting the hoses into the corresponding bottles.

- 7) Insert the detergent and rinse aid inlet hoses into the corresponding bottles.

2.5 Electrical connection

Caution

Electric shock hazard

- The machine must be connected to earth.
- The machine has an external earth-connection screw with the symbol shown;



Information

The connections may only be accessed by qualified personnel [► *Installation qualification* p. 4].

- 1) Before plugging in the machine, make sure that the mains voltage matches the voltage indicated on the machine nameplate.
- 2) Set up the machine
- 3) Disconnect the electrical power supply: unplug the circuit-breaker on the electrical panel corresponding to the external power supply socket of the machine.
- 4) Make the electrical connection according to the type of model and electrical configuration of your machine, as explained in the attached document "Electrical diagram" for each case.
- 5) Prepare a residual current circuit-breaker with a sensitivity of 30 mA and a magneto-thermal circuit-breaker as described in the following table:

Model	Voltage	Cable section	Total Power	Protection
AX-51C	230V/50Hz/1~ 220V/60Hz/1~	3 x 2.5 mm ²	2.7 kW	13 A 2P
	230V/50Hz/1~ 220V/60Hz/1~	3 x 2.5 mm ²	3.7 kW	16 A 2P
	230V/50Hz/1~ 220V/60Hz/1~	3 x 4.0 mm ²	4.7 kW	20 A 2P
	230V/50Hz/1~ 220V/60Hz/1~	3 x 6.0 mm ²	5.7 kW	25 A 2P
AX-100C	400V/50Hz/3N~ 380V/60Hz/3N~	5 x 2.5 mm ²	5.7kW	16 A (3P+N)
	230V/50Hz/1~ 220V/60Hz/1~	3 x 6.0 mm ²	8.25 kW	40 A 2P
	400V/50Hz/3N~ 380V/60Hz/3N~	5 x 2.5 mm ²	8.25 kW	20 A (3P+N)
	230V/50Hz/3~ 220V/60Hz/3~	5 x 6.0 mm ²	8.25 kW	32 A 3P





2.6 First start-up

- 1) Turn on the water stopcock.
- 2) Switch on the circuit-breaker of the electrical panel corresponding to the external power supply socket of the machine.
- 3) [Models without drain pump] Place the overflow pipe in position
- 4) Check that the filters are correctly fitted. [Fig. 4]
- 5) Turn on the machine. [▶ 3.2 Main operating elements p. 7]

2.7 General machine settings

The Ultra dishwasher control panel lets you adjust a wide range of operating parameters. Proceed as follows to edit the values in the options menu.

Editing values

- To change the value of the parameters, press the buttons **PROG**  and **OPTIONAL** :
 - **PROG** button to increase the values.
 - **OPTIONAL** button to decrease the values.
- Press **START**  to confirm and move to the next parameter.
- When the settings are complete, press the **ON/OFF** button  to turn off the machine and confirm the changes.

2.7.1 Initial Settings

Temperature settings

To enter the temperature settings section, when switching on the machine, hold down the **PROG**  and **OPTIONAL**  buttons in the first few seconds while the program is loading:

- **T1 RINSE**: independent rinse temperatures for each cycle/item type. Range: 65 °C- 87 °C (149 °F- 188 °F).
- **T2 WASH**: tank temperature. Range: 40 °C- 70 °C (104 °F- 158 °F).
- **THERMAL LOCK**: thermal lock: *ON-OFF* (LCD: "on-00")
- **INITIAL SETTINGS**: restores initial factory temperature settings.





[Models with electric dispensers] Dispensing and hardness settings





To enter this settings section, when turning on the machine, press and hold the **START** button  in the first few seconds while the program is loading.

Information

The **values shown** are equivalent to two digits to one decimal place. Examples:

- 3.5 g/L: "35" is displayed.
- 0.5 g/L: "05" is displayed.

- **DET DOSE g/l**: dose of detergent in g/L.
- **DET FILL**: detergent priming: *ON-OFF* (LCD: "on-00").
 - a) Press **PROG**  or **OPTIONAL**  to activate (on) the detergent filling process.
 - > The detergent dispenser turns on for a few seconds and then returns to *OFF* (00).
 - b) Press **PROG**  or **START**  again until the pipe is completely filled.
- **R AID DOSE g/L**: rinse aid dose in g/L.

- **R AID DOSE g/L**: rinse aid dose in g/L.
- **RINSE AID FILL**: rinse aid priming: *ON-OFF* (on-00).
 - a) Press **PROG**  or **OPTIONAL**  to activate (on) the detergent filling process.
 - > The detergent dispenser turns on for a few seconds and then returns to *OFF* (00).
 - b) Press **PROG**  or **START**  again until the pipe is completely filled.
- [D models] **WATER HARDNESS**: enter the degree of water hardness (unit: French degree °fH, display shows "°F"). With this data the machine programs the regeneration frequency necessary to inform by means of the icon .

Inlet water hardness	Number of regeneration cycles	
	Automatic cycles	
	AX-51C	AX-100C
0-20 °fH	10	20
21-30 °fH	7	15
31-40 °fH	5	10
41-50 °fH	4	6

Other activations

- [B models] **WATER LEVEL** (qualified technicians only): activation of tank water level display: *ON-OFF* (LCD: "on-00").
 - Cycle times and texts are not displayed.
- [C models] **B.PRES MANUAL**: manual activation of rinse pump: *ON-OFF* (on-00).



2.7.2 Other settings

To enter this settings section, when switching on the machine, press and hold down the **OPTIONALS** button  in the first few seconds while the program is loading.

- **LANGUAGE**
- **RINSE TIME** modification of the time in time range between -2 and +2 seconds (s).
- **ENERGY SAVING**: *ON-OFF* (LCD: "on-00").
- **TEMP UNITS**: selection of temperature units °C/°F.
- **REGEN COUNTER**: displays the number of regeneration cycles performed.
- **CYCLE COUNTER**: displays the number of wash cycles performed.
- **INITIAL SETTINGS**: to restore the initial parameters of the machine.

2.7.3 Screen test

To check that the LCD display segments are working:

- 1) When switching on the machine, press and hold down the **START**  and **OPTIONAL**  buttons simultaneously in the first few seconds while the program is loading.
 - ⇒ All the screen icons light up.



2.7.4 Model settings

If the electronic board is changed or de-configured, the machine requires the model to be adjusted by means of the following adjustment section:

- 1) When switching on the machine, press and hold **PROG** in the first few seconds while the program is loading.
- 2) To choose the model number, press the buttons **PROG** and **OPTIONAL**.
- 3) Confirm your selection by pressing the **START** button.

Model Number	Model
19	AX-51BC
20	AX-51BCD
37	AX-100BC
38	AX-100BCD

Notice

Error with boiler and tank level probes

If the selected model is fitted with boiler and tank level probes and the probes are not connected, an error message is displayed. Conversely, if a model is selected that is not fitted with the probes but the machine has them, an error message is displayed: **E10 TANK LEVEL SENS**

- If this error occurs, reconfigure the machine model for the electronic board.

3 Operation

Warning

Risk of serious injury due to operation when the machine is faulty

Using the machine when it is faulty or in poor condition can affect personal safety and damage the machine.

- If you detect any fault or anomaly in the machine, contact an authorised service agent immediately.

3.1 Preparation for operation

- 1) Before turning on the machine, check the level of detergent and rinse aid in the bottles.
- 2) Open the door/dome and check that all components are in good condition and properly installed:
 - Filters.
 - [Models without drain pump] Overflow.
 - Washing arms (upper and lower).



3.2 Main operating elements

Fig. 2: Control panel and buttons with LEDs

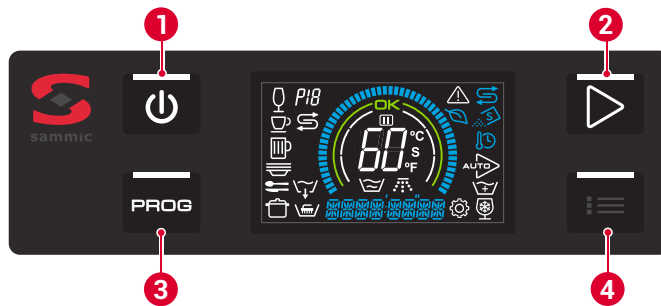

- | | |
|-----------------|-------------------|
| 1 ON/OFF button | 3 PROG button |
| 2 START button | 4 OPTIONAL Button |

Fig. 3: LCD Display

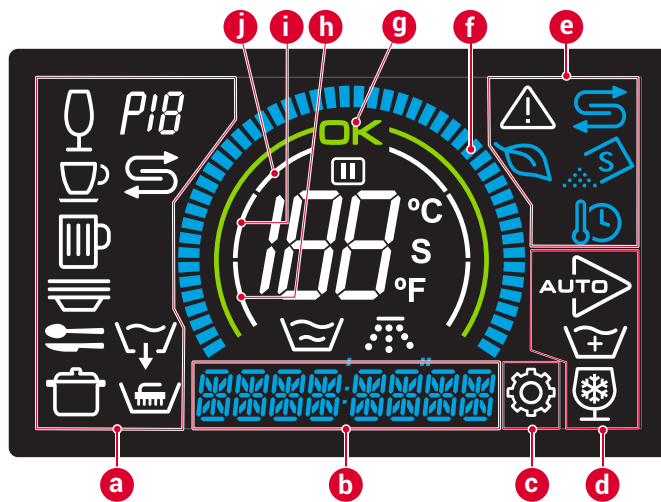

- | | |
|-----------------------------|---|
| a Program/cycle symbols | f Progress bar |
| b Section for text/time | g "Machine ready" arc |
| c Settings section | h Machine water fill blade |
| d Symbols options enabled | i Boiler heating blade during preparation |
| e Indicator/warning symbols | j Tank heating blade during preparation. |

Buttons

ON/OFF button

- Main functions: Turns the machine on and off. When the machine is turned on, the display turns on.
- LED colours:
 - Red: Machine connected and on standby.
 - White: machine on.



START button

- Main functions:
 - Start of the wash cycle.
 - Confirmation of setting parameters.
 - With the door open, activate the "auto start" option.
- LED colours:
 - White: in setting functions.
 - Orange: warming up.
 - Green: machine ready.
 - Blue: cycle in progress.



PROG button

- Main functions: selection of the washing programme.
- LED colours: white. While the button led is on, the display shows the time and temperatures of the tank and boiler corresponding to the selected cycle. [▶ 3.4.2 Program selection p. 8]



OPTIONAL Button

- Main functions:
 - With the door closed, the "wash plus" function is activated. This function extends the selected cycle by 30 seconds
- LED colours:
 - White: access to the settings section.



LCD display indicators/warnings

Icon	Indication/warning
	Tank temperature and washing process.
	Boiler temperature and rinsing process.
	Machine ready. It switches on when the tank has reached the setpoint temperature.
	Settings section: Indicates that the machine is in the operating parameter settings mode.
	Pause: activated when the door is opened during the cycle or when the cycle is extended due to activation of the THERMAL LOCK function or an automatic regeneration cycle. [C models] Also activated if the boiler is not yet completely filled when the rinse starts
	Energy saving mode: After 20 minutes without running a cycle, the boiler setpoint temperature is lowered until the PROG or OPTIONAL buttons are pressed.
	THERMAL LOCK : activated when the boiler has not yet reached the setpoint temperature when the rinse starts.
	Regeneration: ⇒ [D Models] Indicates that the resin regeneration cycle of the descaler is required. ⇒ [CD Models] Indicates that regeneration is being performed.
	[CD models] Low salt indicator. Add salt to regenerate the resins in the descaler.
	Error or fault warning.

3.3 Turning the machine on

- 1) Close the door or dome and press the **ON/OFF** button.
 - ⇒ The orange LED in the **START** button lights up. The machine fills with water and heats it up.
 - ⇒ In the first 3 seconds, it is possible to access the initial settings. The display shows:
 - > Central display: Model number. [Fig. 3/centre] [▶ 2.7.4 Model settings p. 7]
 - > Display, section [Fig. 3/b]: software version.
 - > If the icon appears, the **ENERGY SAVING** function is activated. [▶ 2.7.2 Other settings p. 7]
 - > If the icon appears, the **THERMAL LOCK** function is activated. [▶ 2.7.1 Initial Settings p. 6]
 - ⇒ When the working level is reached, the machine closes the water inlet by means of a pressure switch or level probe fitted in series with the inlet solenoid valve.

- 2) The machine heats up the rinsing boiler and the tank one after the other.
 - ⇒ The machine is ready for use when the pre-set temperatures are reached in the boiler (between 65 and 85 °C. depending on the program) and in the tank (55 °C). The green arc lights up with the **OK** icon on the display and a green LED on the **START** button.
 - ⇒ The estimated time for this operation is approximately 30 minutes.

3.4 Main operation

3.4.1 Prewash

- 1) Remove any remaining dirt and rinse the items before putting them in the dishwasher.
- 2) Place the items in the dishwasher basket.
- 3) When the basket is full, open the door or dome of the machine and insert the basket centred on the support rails.

3.4.2 Program selection

- 1) To select the wash program that best suits the type of item you want to wash, press the **PROG** button .
- 2) Select the type of wash cycle by successively pressing the **PROG** button .
 - While the led of the **PROG** button is on, the display shows the time and tank and boiler temperatures corresponding to the selected cycle.
 - When the LED goes out, the display shows the actual temperatures.

Icon	Description	Icon	Description
	GLASSES Cycle		DISHES Cycle
	CUPS cycle		CUTLERY cycle
	JUGS cycle		PANS cycle
	DRAIN Cycle Selectable with door/dome open.		

3.4.3 Washing



- 1) Press the **START** button to start the wash cycle in the machine.
 - To move to the next phase of the wash cycle, press **START** successively.
 - If the **THERMAL LOCK** function is active, the machine does NOT respond to buttons being pressed.
 - If the door is opened, the machine pauses the cycle and the icon comes on.
 - [Models with drain pump] The icon flashes during the drain phase prior to the rinse process.

Caution

Risk of irritation from splashes

If you open the door or dome in the middle of the cycle, the machine may spray soapy water at high temperature and, if it comes into contact with the skin or mucous membranes, it may cause irritation.

- Do not open the door or dome in the middle of the cycle.

- 2) During the washing phase, the icon  and the temperature of the wash tank are displayed.
- 3) During the rinsing phase, the icon  and the boiler temperature are displayed.
- 4) When the wash cycle is finished, the machine informs you with the following messages:
 - 3 acoustic warnings ("beep")
 - The blue progress crown is complete and flashing.
 - The light of the START button  flashes blue.
 - The countdown shown on the screen has come to an end.





Caution

Risk of irritation from high temperature water vapour

After the end of the wash cycle, when you open the door or dome of the dishwasher, a large amount of steam comes out at high temperature and may irritate the skin or eyes. The items may be at high temperature and cause minor skin irritation/burns.

- When opening the door or dome of the machine, avoid bringing your face close to the machine.
- If steam gets on your face, wash your face with cool water.
- Wait a reasonable amount of time before removing items from the dishwasher.

- 5) Open the door or dome and remove the basket from the dishwasher.
 - 6) If you want to wash more baskets, repeat the process from step 3.4.1-1).
- ⇒ If the **PROG**  or **START** button  is not pressed within 2.5 hours, the machine switches off automatically.

4 Maintenance and troubleshooting

Fig. 4: Machine filters

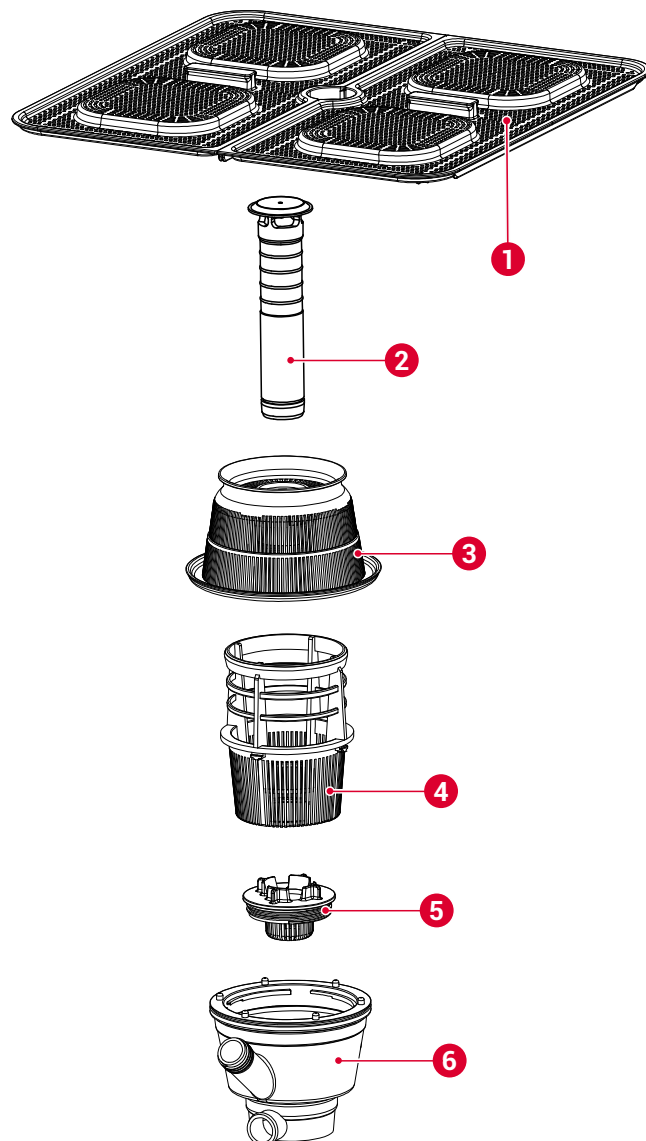

1 Surface filters	4 Suction filter
2 Overflow	5 Drain filter
3 Collector filter	6 Collector

4.1 Safety information

- **Risk of scalding with the water in the tank:** the water in the tank is at a temperature of approx. 60 °C.
 - ⇒ Do not put your hands in the tank for a prolonged period of time.
 - ⇒ When emptying or cleaning the tank manually, wear waterproof rubber gloves.
- **Risk of burns with the heating element:** the surface of the heating element is subject to residual heat after use.
 - ⇒ Avoid placing your hands close to the heating element after using the machine.

- **Risk of skin irritation and chemical burns from contact with the wash water:** the water contains dissolved industrial detergent.
 - ⇒ Wear waterproof rubber gloves when you have to put your hands in the tank (emptying the tank) or when you have to handle the detergent or rinse aid bottles.
 - ⇒ Wash your hands immediately if they come into contact with the wash water.

4.2 Machine maintenance

4.2.1 Maintenance plan

Minimum frequency	Task	Actions
Daily	Drainage	[▶ 4.2.2 Daily drainage of the machine p. 10]
Daily	Self clean	[▶ 4.2.3 Daily cleaning of the machine p. 10]





(*) Frequency of regeneration of the descaler according to water hardness and the washing cycles carried out: **2.7.1** "[Models with electric dispensers] Dispensing and hardness settings " [▶ p. 6].

4.2.2 Daily drainage of the machine

[Neutral models and D models]

- 1) Open the door and remove the surface filter [Fig. 4/1]
- 2) Disconnect the overflow [Fig. 4/2].
 - ⇒ The water in the tank is drained by gravity.

[Models with drain pump]

- 1) Open the door.
- 2) Press the **PROG** button  to choose from the following options:
 - Drainage 
 - Self-cleaning and drainage 
- 3) Close the door and press **START**  to begin the regeneration cycle.
 - Drainage
 - i) The machine stops heating the elements. 
 - ii) The drain pump drains the water from the tank until the probe detects that it has been fully drained.
 - iii) The machine switches off automatically at the end of the drainage cycle.

4.2.3 Daily cleaning of the machine

Warning

Risk of death or serious injuries from electric shock

- Before cleaning the machine, turn off and unplug the machine.

Notice

Risk of damaging the machine due to water ingress

- Prevent water from entering the machine.
- Do not clean the machine under running water.
- Do not immerse the machine in water.

Notice

Risk of rust on the machine

- Do not clean the machine with abrasive detergents (nitric acid, bleach, solvents, sandy detergents, etc.).
- Do not clean the machine with metal scrapers or scouring pads.

- 1) Empty the tank (4.2.2).
- 2) [Neutral and D models] To turn off the machine, press the ON/OFF button .
- 3) Disengage the wash arms (upper and lower).
- 4) Remove the complete filter set:
 - Surface filters [Fig. 4/1]
 - Collector filter [Fig. 4/3]
 - Suction filter [Fig. 4/4]
 - [Models with drain pump] Drain filter [Fig. 4/5]
- 5) Clean the filters and arms:
 - Remove food debris and other residue from the disassembled elements.
 - Make sure in particular that the nozzles of the wash arms are free of any impurities and/or limescale.

Warning

Risk of burns with heating element

The surface of the heating element maintains residual heat after use.

- Avoid placing your hands close to the heating element after using the machine.

- 6) Clean the inside and outside of the machine with a damp cloth and neutral soap. Remove any residue that may remain on the surface of the tank.
- 7) Connect the filters and wash arms in reverse order of disassembly as described in step 2).

4.2.4 Regeneration of the descaler





[BCD and BCDV models]

Required tools: funnel and salt (not included in the supply).

The machine regenerates the resins of the descaler automatically. The frequency depends on inlet water hardness and the number of cycles performed.

- Start of the automatic regeneration cycle after each machine power-up:

Prerequisites: machine switched on and tank empty. [▶ 4.2.2 Daily drainage of the machine p. 10]

 - a) If the boiler is not full, it will fill the boiler before the regeneration cycle.
 - b) The machine starts the automatic regeneration cycle with the icon  on. The cycle time is approximately 180 seconds. After regeneration, the tank filling sequence starts.
- Operation during normal work cycle: the regeneration cycle is performed according to the value entered in the water hardness setting mode.
 - a) The regeneration cycle starts after completion of the boiler filling process in the previous cycle. The display shows the icons  and .
 - > If a wash cycle starts after the regeneration cycle has begun, the wash cycle is extended until the regeneration is complete.
 - b) If there is a lack of salt, the display shows the flashing  icon. The icon  also lights up.
 - > The regeneration process takes place anyway.
 - > Both icons remain lit until you refill the salt tank.



Notice

Risk of damaging the machine due to excess salt

Salt is highly corrosive and could cause damage.

- Use the funnel to direct the salt into the tank to avoid spilling salt into the tank.
- Immediately wipe off any excess salt with a damp cloth.

- c) Open the dishwasher door and fill the salt container with dishwasher salt until the water overflows from the container (a full container lasts up to 3 cycles).

4.3 Troubleshooting

Troubleshooting qualification: Troubleshooting for this machine is allowed by *Sammic*-approved service companies and technicians.

Error messages on the screen

Code	Text on screen	Description
E1	BOIL TEMP PROBE OFF	Boiler temperature probe not connected (open circuit)
E2	BOIL TEMP PROBE OFF	Short-circuited boiler temperature probe
E3	TANK TEMP PROBE OFF	Tank temperature probe not connected (open circuit)
E4	TANK TEMP PROBE OFF	Short-circuited tank temperature probe
E5	RINSE TEMP PROBE OFF	Rinsing temperature probe with open circuit
E6	RINSE TEMP PROBE OFF	Short-circuited rinse temperature probe
E7	BOIL FILL TIMEOUT	Cycle time exceeded, boiler overheating failure (with THERMAL LOCK)
E8	BOIL FILL TIMEOUT	Boiler fill fault: no water before rinsing
E9	RINSE LEVEL ERROR	Rinse fault: high level detection end of rinse
E10	TANK LEVEL SENS OFF	Tank level probe disconnected
E11	TANK LEVEL SENS OFF	Boiler level probe disconnected
E12	TANK LEVEL TOO HIGH	Excess level in the tank
E13	DRAIN CYCLE TIMEOUT	Excessive drainage time in cycle
E14	DRAIN CYCLE TIMEOUT	Excessive drainage cycle time
E15	MODEL NUMBER ERROR	Model number fault
E16	BOIL FILL TIMEOUT	Excessive boiler filling time

LED signals on the electronic board

- 1) For access to the electronic board and wiring: turn off the power supply at the main switch of the machine and at the automatic protection switch on the external power supply socket of the machine.

The electronic board consists of a series of light indicators that are very useful when it comes to seeing the operation of the machine or detecting faults.

Information

See also the last figures in the appendix at the end of the manual with the two electronic board variants:

- [Neutral, CB, BCD, BV, BVC, BCDV models] **L VX board**

The indicators are divided into two groups, input and output indicators:

- **Yellow input indicator LEDs:** they show the information received by the electronic board.

Name of the yellow LED	Description
<i>DOOR</i>	Door closed.
<i>PRESOST</i>	High pressure switch activated, tank full.
<i>SAL</i>	Indicates the presence of salt for resin tank regeneration.

- **Red output indicator LEDs:** they show the element activated by the microprocessor.

Name of the red LED	Description
Relay <i>M1</i>	Washing pump
Relay <i>C2 CUBA</i>	Tank element
Relay <i>ON/OFF</i>	General connection
Triac <i>C1 CALD</i>	Boiler element contactor
Triac <i>B.VAC</i>	Drain pump activated.
Triac <i>EV1</i>	Hot water solenoid valve activated.
Triac <i>EV REG/F</i>	[Models D, BD, BCD, BCDV] Regeneration or cold water solenoid valve.
Triac <i>D.DET</i>	Detergent dispenser.
Triac <i>D.ABR</i>	Rinse aid dispenser.
Triac <i>EV CALD</i>	[BCD, BCDV, models] Boiler solenoid valve-drainage
Triac <i>B.PRES</i>	[BC, BCD, BCDV Models] Rinse pressure pump
Triac <i>VENT</i>	[BV, BCDV and BCDV Models] Steam condenser fan
<i>B.DESC</i>	[BCD and BCDV Models] Automatic descaler pressure pump

4.4 Spare parts and accessories

4.4.1 Spare parts

For spare parts, see the "Spare parts exploded view" document supplied with the machine.

4.4.2 Accessories

Information

The reference numbers of the accessories are available in the "Spare parts exploded view" document supplied with the machine.

Detergent dispenser

Caution

Electric shock hazard

Installing a dispenser involves access to power cables.

- Switch off the machine and disconnect the machine from the mains before installing the dispenser

The machine is prepared for the installation of a third-party adjustable detergent dispenser pump. Maximum power allowed: 10 W.

To install adjustable detergent dispensers, proceed as follows:

- 1) Access to the DD power strip on the lower front part of the machine for the electrical connection of the soap dispenser. This strip is controlled by solenoid valve EV1. Refer to the wiring diagram for the correct connection order.
- 2) Install the soap injection fitting through the hole at the rear.

i Information

Sammic declines all liability for defects caused by faulty connections when installing the dispensers.

Rinse aid dispenser

Mains water dispenser

- 1) Check that the rinse aid tank is full.
- 2) Start the machine and stop the wash/rinse cycle 5 or 6 times by successively pressing the **PROG** button  checking that the rinse aid pipe fills up and the rinse aid enters the boiler.
 - ⇒ The rinse aid can be adjusted using the adjustment screw on the lower front part in the direction indicated.

Peristaltic dispenser

- The dose is adjusted in the settings section of the control panel. [▶ p. 7]
- During installation, prime the detergent pipe from the settings section [▶ p. 7].
- To check if the dose of rinse aid is effective, hold the glasses up to the light.
 - If there are drops of water on the glass, the dose is insufficient
 - If there are streaks on the glass, the dose is too high.

Installation with descaler

Install a Sammic descaler when the limescale content in the machine feed water exceeds 10 °fH (French grade).

- Installation instructions are supplied with the descaler.
- Avoid flow reductions (choking) before and after installation, as they cause pressure losses.

Installation with back-up valve

Install a back-up valve when the water pressure to be supplied to the machine is lower than the pressure specified for that model.

- The back-up valve can be installed at any point near the unit, extending the water line and stopcock to the back-up valve.
- Make sure that the stopcock is still accessible.
- Connect one end of the back-up valve to the stopcock and the other end to the hose supplied with the machine.

5 Disposal

Packaging

Follow current environmental standards in your country to dispose of the packaging.

Machine

This machine is subject to the provisions of European Directive 2012/19/EU on waste electrical and electronic equipment. The machine is marked with the *WEEE* (Waste of Electrical and Electronic Equipment) symbol:

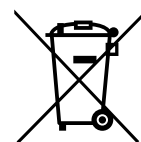

- ⇒ Do not dispose of this machine in normal household waste.
- ⇒ Dispose of the machine at an authorised waste management centre or through municipal waste disposal entities. Comply with the applicable regulations.

You can obtain information about waste disposal and the location of your nearest recycling centre, for example, from your municipal cleaning service.

6 Technical specifications

Front glasswashers and dishwashers

Specifications	AX-51C Front	AX-100C Passthrough
Basket dimensions [mm]	500 x 500	
Maximum crockery height	365 mm	440 mm
Provision of baskets	2	3
Cycle [s]	90/120/180	
Basket production/h	40/30/20	
Electrical power supply	400 V/50 Hz/3~ 230 V/50 Hz/1~	
Electric power		
Motor pump	500 W/0,7 HP	700 W/1 HP
Washing power	1,800 W	2,500 W
Boiler power	5,000 W	6,000 W
Total power	5,750 W	6,750 W
Temperatures		
Washing	40-70 °C (104-158 °F)	
Rinse	65-87 °C (149-189 °F)	
Water capacity		
Wash tank	14.0 L	25.0 L
Rinse boiler	8.0 L	12.0 L
Water consumption (2 bar)	2.5 L	2.7 L
External Dimensions		
Width [mm]	580	648 (732 [*])
Depth [mm]	635	756 (860 [*])
Height [mm]	830	2000 (1508 [†])

[*] Width with lifting bar included.

[†] Height with dome closed.

Fig. C: AX-51C

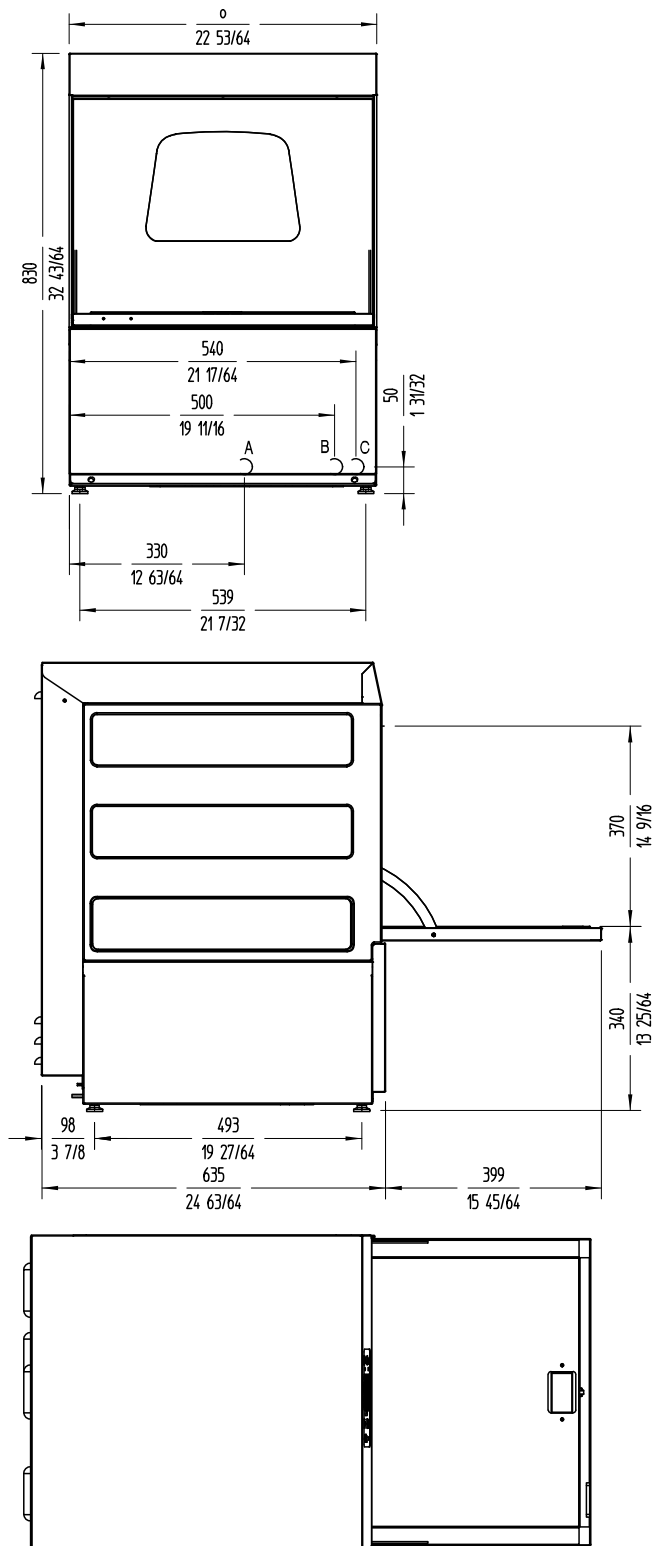
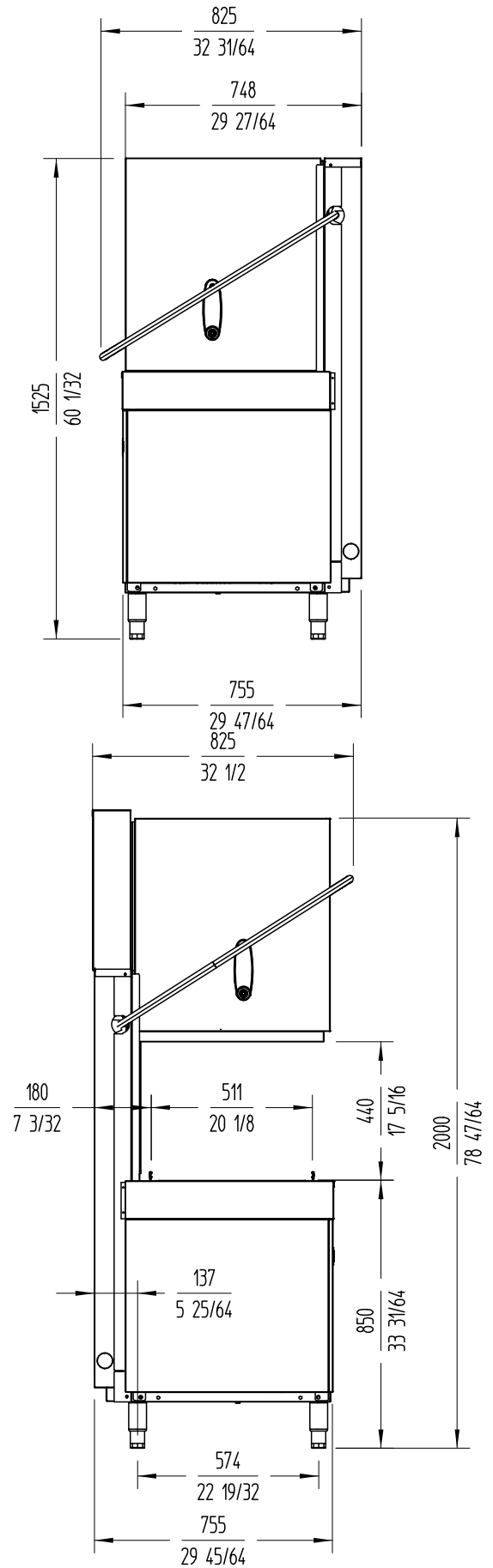
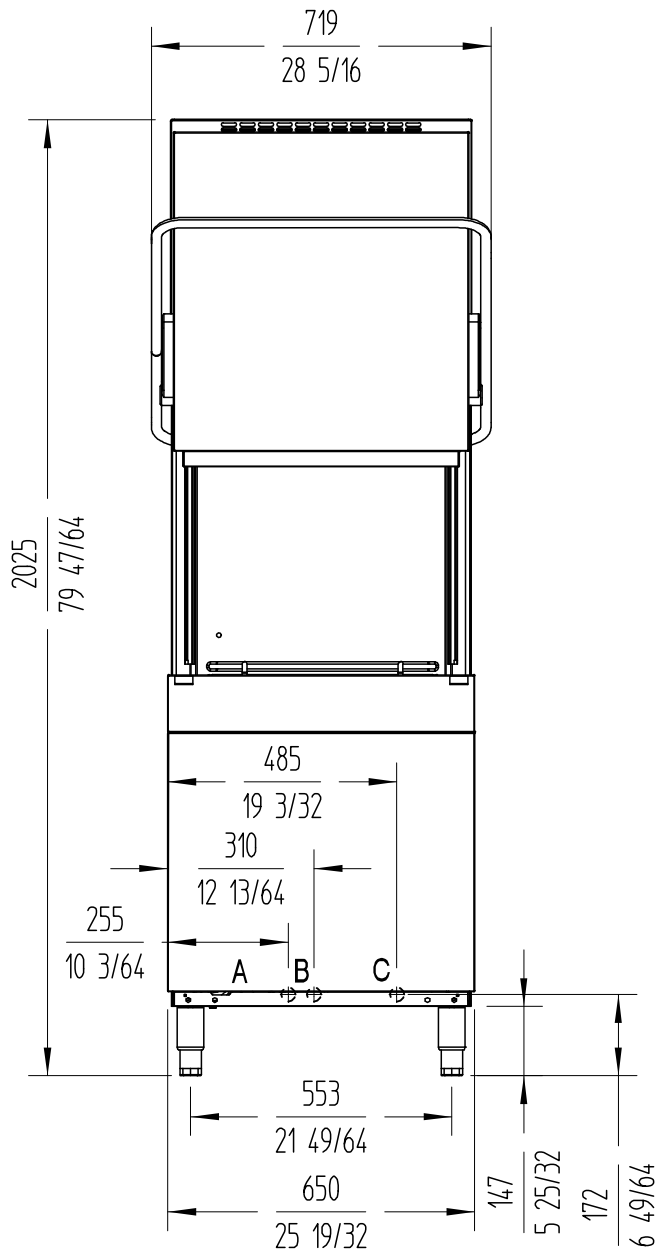

Fig. D: AX-100C



EN

Fig. E: AX-100C



[EN] Electronic board

Fig. G: LVX

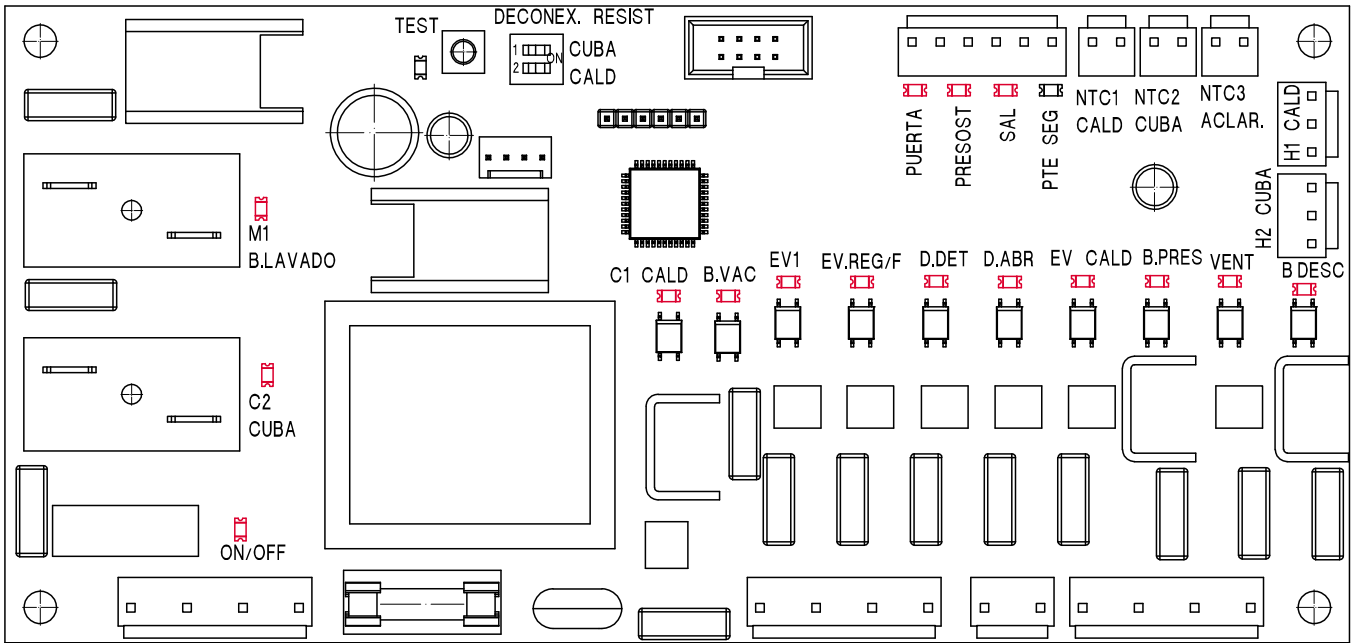

EN

