



SPREMIAGRUMI ECP

Spremiagrumi con pressione a leva.



MODELLI DISPONIBILI

3420033 Spremiagrumi ECP 230/50/1

3420034 Spremiagrumi ECP 120/60/1

3420035 Spremiagrumi ECP 220/60/1

* Consulta per versioni speciali

DESCRIZIONE COMMERCIALE

Per tutte le tipologie di strutture.

- ✓ Corpo in acciaio inox.
- ✓ Pressione tramite leva.
- ✓ Massima igiene: minimizza il contatto della mano con il prodotto.
- ✓ Facile da usare e da pulire.
- ✓ Molto resistente.

OPZIONALE

- Colino esterno d'acciaio inossidabile.
- Caraffa d'acciaio inossidabile (1.5 litri).

ACCESSORI

- Colino esterno spremiagrumi
- Caraffa per spremiagrumi

SPECIFICHE

Produzione arance/ora: 200

Potenza Totale: 130 W

Dimensioni esterne

- ✓ Larghezza: 200 mm
- ✓ Profondità: 300 mm
- ✓ Altezza: 370 mm

Peso netto: 8 kg

Livello di rumore (1 m.): 60 dB(A)

Rumore di fondo: 25 dB(A)

Dimensioni del pacchetto

300 x 300 x 445 mm

Peso lordo: 9.8 kg



CAFFETTERIA-BUFFET
SPREMIAGRUMI PROFESSIONALI

scheda del prodotto
aggiornato 25/11/2024



SPREMIAGRUMI ECP

Spremiagrumi con pressione a leva.



CAFFETTERIA-BUFFET
SPREMIAGRUMI PROFESSIONALI

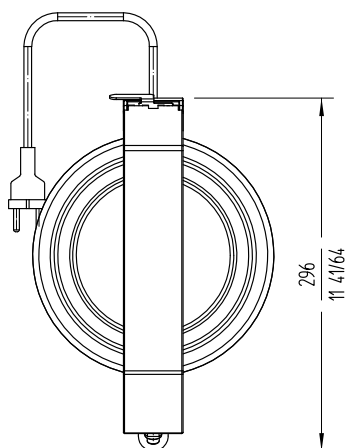
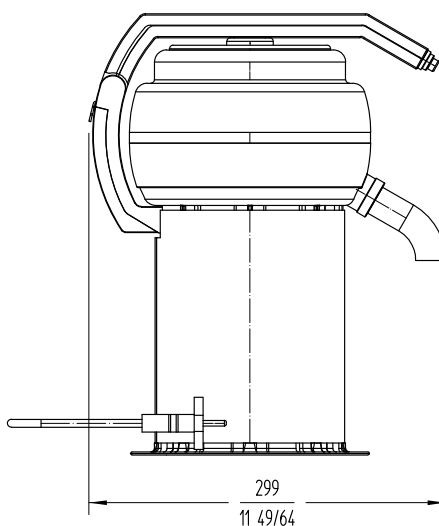
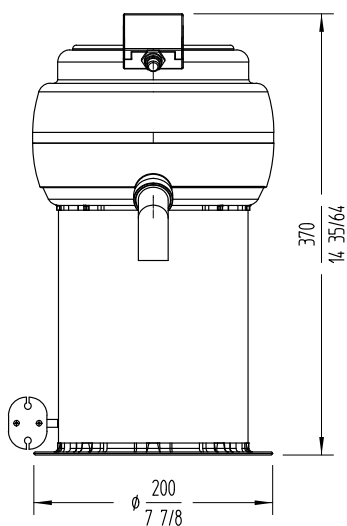

www.sammic.it

Food Service Equipment Manufacturer
Via M. Bignamini 2/C
24047 - Treviglio (BG)
italia@sammic.com
Tel.: +39 0363 1847403



Progetto	Data
Rif.	Unità
Approvato	

scheda del prodotto
aggiornato 25/11/2024