



PLANETARY MIXER BE-30

Floorstanding unit with 30 l / 30 qt bowl.



DYNAMIC PREPARATION
PLANETARY MIXERS



SALES DESCRIPTION

“C” models, equipped with attachment drive for accessories.

“I” models with stainless steel column.

Professional food mixer for preparing dough (bread, cake...), egg whites (soufflés, meringue...), sauces (mayonnaise...) and minced meat mixtures.

- ✓ Powerful three-phase motor controlled by highly reliable electronic speed variator technology, which enables the mixers to be connected to a single-phase electrical mains supply.
- ✓ 0-30 minute electronic timer and continuous operation option.
- ✓ Acoustic alarm at end of cycle.
- ✓ Electronic speed control.
- ✓ Equipped with a safety guard.
- ✓ Lever operated bowl lift.
- ✓ Double micro switch for bowl position and safety guard.
- ✓ Safeties off indicator.
- ✓ Reinforced waterproofing system.
- ✓ Stainless steel legs.
- ✓ Strong and resistant bowl.
- ✓ Easy to maintain and repair. UNE-EN 454/2015 compliant.

INCLUDES

- ✓ Stainless steel bowl.
- ✓ Beater spatula for soft dough.
- ✓ Spiral hook for heavy dough.
- ✓ Balloon whisk.

OPTIONAL

- Attachment drive for accessories.
- Bowl transport trolley.
- Stainless steel column.
- Base kit with wheels for ease of moving and storing the mixer.
- 10 l / 10 qt reduction equipment (bowl + tools).

ACCESSORIES

- Vegetable preparation attachment CR-143
- Meat mincer attachment HM-71
- Potato masher attachment
- P-132
- Bowls for planetary mixers
- Reduction equipments
- Bowl transport trolleys
- Base kit with wheels

SPECIFICATIONS

Bowl capacity: 30 l
 Bowl dimensions: 380 mm x 340 mm
 Capacity in flour (60% water): 9 kg
 Timer (min-max): 0' - 30'
 Tool speed: 87 - 378 rpm
 Planetary speed: 39 - 168 rpm
 Total loading: 1100 W

External dimensions (W x D x H)

- ✓ Width: 528 mm
 - ✓ Depth: 764 mm
 - ✓ Height: 1152 mm
- Net weight: 105 kg
 Noise level (1m.): <75 dB(A)
 Background noise: 32 dB(A)

AVAILABLE MODELS

- 1500280 Food mixer BE-30 230/50-60/1
- 1500282 Food mixer BE-30I 230/50-60/1
- 1500281 Food mixer BE-30C 230/50-60/1
- 1500286 Food mixer BE-30 400-440/50-60/3
- 1500291 Food mixer BE-30I 208-240/50-60/1
- 1500287 Food mixer BE-30C 400-440/50-60/3

* Ask for special versions availability



product sheet
updated 30/01/2024



PLANETARY MIXER BE-30

Floorstanding unit with 30 l / 30 qt bowl.



DYNAMIC PREPARATION
PLANETARY MIXERS

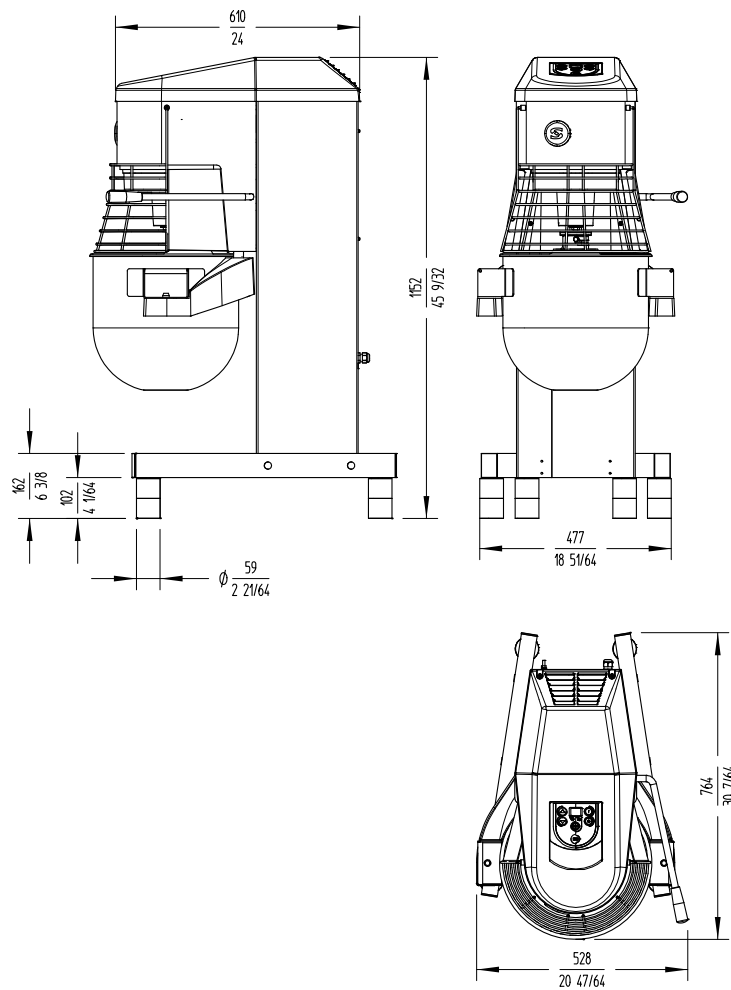

www.sammic.co.uk

Food Service Equipment Manufacturer

Unit 2, Trevanth Road

Troon Industrial Park

LE4 9LS - Leicester

uksales@sammic.com

Tel.: +44 0116 246 1900



Project

Date

Item

Qty

Approved

product sheet
updated 30/01/2024