



# PASS-THROUGH WAREWASHER UX-130BC

Pass-through glass- and dishwasher. Rack size 500 mm x 500 mm and door clearance 430 mm.



WARE WASHING  
PASS-THROUGH WAREWASHERS



- ✓ “Flow” opening mechanism: allows the hood to be raised with less effort
- ✓ High load capacity 43 cm: suitable for GN 1/1 and Euronorm
- ✓ Stainless steel surface filters for greater stability and resistance during intensive use

### Premium warewashing

- ✓ Soft start: progressive start-up of the washing pump to protect fragile items.
- ✓ Top panel: it allows quick and intuitive reading of information, ideal for corner installations.
- ✓ Colour LCD Display: intuitive communication of the machine status by means of messages, colour codes and icons.
- ✓ Dedicated cycles: selection of the ideal washing programme using icons.
- ✓ Adaptable: allows the main parameters of the machine to be adjusted to the needs of each user.
- ✓ TEMPERATURE DISPLAY
- ✓ Wash Plus+ function: increases the intensity of the wash cycle for greater cleaning performance
- ✓ Control panel with IP65 humidity protection.

### You will never WASH ALONE

- ✓ Tech-Services: our team of technicians will help you so that your machine is always ready for use.
- ✓ Design Services: tell us what your needs are and we will advise you.
- ✓ 60 years of experience and know-how at your disposal.

## SALES DESCRIPTION

- ✓ Top panel.
- ✓ Sani-Control: guaranteed disinfection.
- ✓ Exclusive Hydroblade™ washing arms: maximum effectiveness.
- ✓ 3-stage filtering system.

### Sani-Control guarantee

- ✓ GUARANTEED DISINFECTION in compliance with standard DIN 10534.
- ✓ THERMAL LOCK function: Ensures that rinsing will be carried out at the ideal temperature to disinfect the dishes.
- ✓ CONSTANT HIGH TEMPERATURE RINSE system for optimal disinfection.
- ✓ The PRESSURE PUMP guarantees effective high-pressure rinsing
- ✓ WRAS certified.

### New recessed bodywork

- ✓ Ergonomic design with rounded corners to prevent the accumulation of dirt and facilitate cleaning.
- ✓ Compact tank volume (50% water saving compared to the previous range).

### Hydroblade™ washing arms

- ✓ Redesigned nozzles for greater washing performance.
- ✓ The “monoblock” design delivers durability and resistance to impacts.
- ✓ 30% savings in water consumption during rinsing compared to the previous range.

### 3-stage filter system: surface, tank and extraction

- ✓ Keeps the washing water in optimal conditions to maintain constant washing performance.

### Designed to last

## INCLUDES

- ✓ Peristaltic detergent pump.
- ✓ Drainage pump with level sensor. Proactive tank water renewal.
- ✓ Type-A air break. WRAS approved break tank.
- ✓ Rinse aid pump.
- ✓ 1 glasses basket.
- ✓ 1 mixed basket (plates).
- ✓ 1 cutlery basket.

## ACCESSORIES

- Tables for pass-through dishwashers
- Manual water softeners
- Automatic water softeners
- 500 x 500 mm baskets
- Inserts & supplements
- Central sorting tables
- Double connection central sorting table
- Prewashing tables for pass-through and rack conveyor dishwashers
- Connecting tables for pass-through dishwashers and rack conveyors
- Reverse osmosis devices OS-140
- Dosing equipments for AX / UX hood-type dishwashers

## SPECIFICATIONS

Basket dimensions: 500 mm x 500 mm  
Useful height: 430 mm

Cycles: 6  
Cycle duration: 60 / 90 / 100 / 150 / 210”  
Production baskets / hour: 60 / 40 / 36 / 24 / 17

Boiler capacity: 12 l  
Wash tank capacity: 25 l

### Consumption and savings

- ✓ Water consumption/cycle: 2.8 l
- ✓ Automatic saving mode in: 25’



product sheet  
updated 12/03/2025



# PASS-THROUGH WAREWASHER UX-130BC

Pass-through glass- and dishwasher. Rack size 500 mm x 500 mm and door clearance 430 mm.



WARE WASHING  
PASS-THROUGH WAREWASHERS

✓ Automatic switch-off: 120'

### Energy consumption

**Water consumption/cycle (kWh): [v:cons\_ciclo\_kwh]**  
**Tank filling consumption (kWh): [v:cons\_llenado\_cuba\_kwh]**

Loading\_\_

- ✓ Pump: 1000 W / 1.3 Hp
- ✓ Tank: 3000 W
- ✓ Boiler: 9000 W
- ✓ Total loading: 10000 W

### External dimensions (W x D x H)

- ✓ Width: 650 mm (Wide with handle: 725 mm)
- ✓ Depth: 755 mm (Bottom with handle: 835 mm)

✓ Height: 2070 mm / 1600 mm

Wash temperature: 71°C  
 Rinse temperature: 87°C  
 Noise level (1m.): <70 dB(A)

Crated dimensions  
 760 x 860 x 1630 mm  
 Gross weight: 133 kg

### AVAILABLE MODELS

1303430 UX-130BC 400/50/3N DD

\* Ask for special versions availability

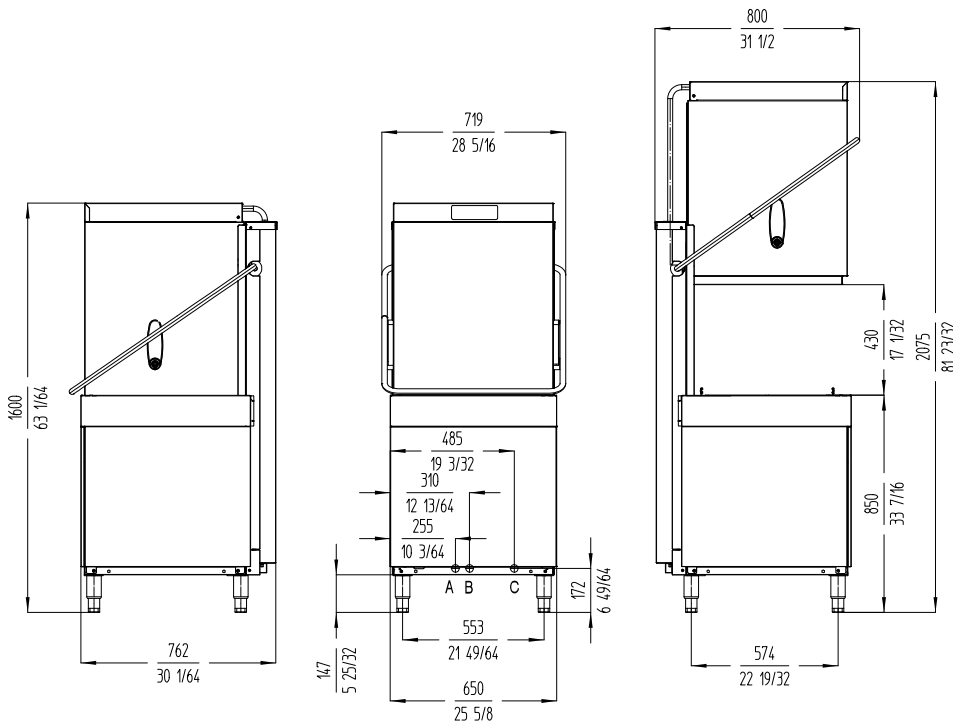

A: Entrada de agua 3/4" GAS  
 B: Tuboi de desague  
 C: Cable conexión



sammic.co.uk

Food Service Equipment Manufacturer  
 Unit 2, Trevanth Road  
 Troon Industrial Park  
 LE4 9LS - Leicester  
 uksales@sammic.com  
 Tel.: +44 0116 246 1900



Project

Date

Item

Qty

Approved

product sheet  
updated 12/03/2025