



# GLASSWASHER AX-40

Rack size 400 mm x 400 mm and door clearance 300 mm.



WARE WASHING  
COMMERCIAL GLASSWASHERS



### “Easy grip” door: new design with integrated door handle

- ✓ Designed to have no corners or areas that are difficult to access: prevents deposits of dirt and facilitates cleaning.
- ✓ Its ergonomic handle provides a perfect grip, even with wet hands.
- ✓ 300 mm load capacity: high versatility for washing a wide range of glasses and even medium-sized dishes.
- ✓ Double-walled door with safety microswitch and high quality seal.

### Warewashing, made simple

- ✓ Active Xperience: simple and intuitive use.
- ✓ Dedicated cycles: selection of the ideal washing programme using icons.
- ✓ Electronic control panel with IP65 humidity protection.

### You will never WASH ALONE

- ✓ Tech Services: our team of technicians will help you so that your machine is always ready for use.
- ✓ Design Services: tell us what your needs are and we will advise you.
- ✓ 60 years of experience and know-how at your disposal.

### INCLUDES

- ✓ Rinse aid pump.
- ✓ 1 glasses basket.
- ✓ 1 mixed basket (plates).
- ✓ 1 small basket for cutlery.

### OPTIONAL

- Detergent dosing kit.
- Overflow drainage pump. Tank water renewal by the principle of density.
- Double-level accessory for washing two baskets at the same time.

### ACCESSORIES

- Manual water softeners
- Automatic water softeners
- 400 x 400 mm baskets
- Inserts & supplements
- High feet kit
- Reverse osmosis devices OS-140
- Dosing equipments front AX / UX glass- and undercounter dishwashers
- Double rack kits for AX/UX

### SPECIFICATIONS

Basket dimensions: 400 mm x 400 mm  
Useful height: 300 mm

Cycle duration: 120 / 150 / 210" (Optional: 90 / 120 / 180")  
Production baskets / hour: 30 / 24 / 17 (Optional: 40 / 30 / 20)

Boiler capacity: 3,2 l  
Wash tank capacity: 9 l  
Water consumption/cycle: 2,2 l

### Energy consumption

- ✓ Water consumption/cycle (kWh): 0,17 kWh
- ✓ Tank filling consumption: 0,39 kWh

### Loading

- ✓ Pump: 250 W / 0.33 Hp
- ✓ Tank: 1200 W
- ✓ Boiler: 2500 W
- ✓ Total loading: 2750 W

### SALES DESCRIPTION

- ✓ Sani-Control: guaranteed disinfection.
- ✓ Embedded bodywork and easy-grip door: hygienic and ergonomic.
- ✓ Exclusive Hydroblade™ washing arms: maximum effectiveness.
- ✓ 3-stage filtering system.
- ✓ Double-walled body (partial).

### Sani-Control guarantee

- ✓ GUARANTEED DISINFECTION in compliance with standard DIN 10534.
- ✓ THERMAL LOCK function: ensures that rinsing will be carried out at the ideal temperature to disinfect the dishes.

### New recessed bodywork

- ✓ Ergonomic design with rounded corners to prevent the accumulation of dirt and facilitate cleaning.
- ✓ Compact tank volume (50% water saving compared to the previous range).
- ✓ Embedded basket guides.

### Hydroblade™ washing arms

- ✓ Redesigned nozzles for greater washing performance.
- ✓ The “monoblock” design delivers durability and resistance to impacts.
- ✓ 30% savings in water consumption during rinsing compared to the previous range.

### 3-stage filter system: surface, tank and extraction

- ✓ Keeps the washing water in optimal conditions to maintain constant washing performance.
- ✓ The surface filters feature an “easy-on” design and can be quickly removed without having to disconnect the washing arms.



product sheet  
updated 12/03/2025



# GLASSWASHER AX-40

Rack size 400 mm x 400 mm and door clearance 300 mm.



WARE WASHING  
COMMERCIAL GLASSWASHERS

Electrical connection: .

### External dimensions (W x D x H)

- ✓ Width: 470 mm
- ✓ Depth: 537 mm
- ✓ Height: 710 mm

Noise level (1m.): <69 dB(A)

Crated dimensions  
525 x 615 x 820 mm

### AVAILABLE MODELS

1303080 AX-40 230/50/1

1303081 AX-40 220/60/1

1303087 AX-40B 230/50/1

1303088 AX-40B 220/60/1

\* Ask for special versions availability

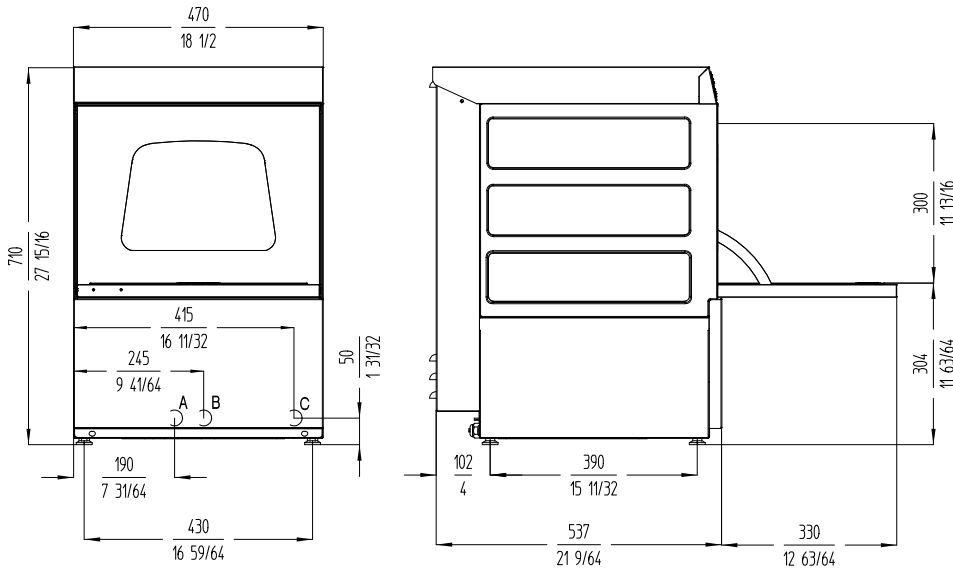

A: Entrada de agua 3/4" GAS.  
 B: Tubo de desague Ø30 mm.  
 C: Cable conexión.

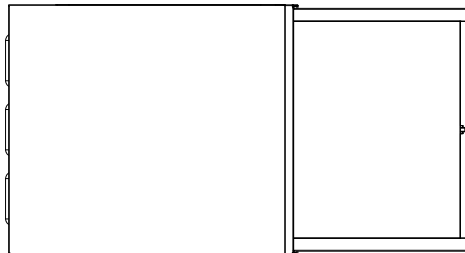

**sammic** | sammic.com  
 Food Service Equipment Manufacturer

Polígono Basarte, 1. phone +34 943 15 72 36  
 20720 Azkoitia, Spain sales@sammic.com



Project	Date
Item	Qty

Approved

product sheet  
updated 12/03/2025