



# VACUUM SEALER SU-810LL

Floorstanding unit. 100m³/h. 848+848 mm.



FOOD PRESERVATION AND SOUS-VIDE  
VACUUM PACKING MACHINES • SENSOR ULTRA LINE



## SALES DESCRIPTION

Two sealing bars (848+848 mm.)  
100 m³/h Busch vacuum pump.  
Vacuum controlled by sensor.

- ✓ Powered by Busch.
- ✓ Vacuum controlled by sensor.
- ✓ Vacuum PLUS.
- ✓ LCD colour screen: all information at a glance.
- ✓ Backlit touch keyboard.
- ✓ Programmable: 25-programme memory. Blocking option.
- ✓ "Pause" button.
- ✓ Phased vacuum programme.
- ✓ Detection of the evaporation of liquids.
- ✓ Double seal.
- ✓ Cordless sealing bar.
- ✓ Progressive decompression.
- ✓ Vac-Norm ready with Automatic decompression.
- ✓ Stainless steel body and chamber.
- ✓ Damped transparent lid.
- ✓ Dry-oil programme for drying the pump.
- ✓ Working hours counter for oil changes.
- ✓ Safety system with protection against vacuum failure.
- ✓ NSF-listed.

## INCLUDES

- ✓ BUSCH pump.
- ✓ Wireless connectivity.
- ✓ Sensor controls.
- ✓ Programmable.
- ✓ Vacuum PLUS: up to 10 seconds of extra vacuum pull.
- ✓ Soft air function.
- ✓ Clear methacrylate lid.
- ✓ "PAUSE" function.
- ✓ Liquid detection system.
- ✓ Dry oil cycle.
- ✓ NSF approved.
- ✓ Filling plate.

## OPTIONAL

- Inert gas
- Sealing plus
- Printer
- Vacuum packing bags
- External vacuum kit for
- Vac-Norm, containers and accessories
- Bag cutting kit
- Support for liquid packaging
- Additional filling plates

## ACCESSORIES

- Bag cutting kits
- Filling plates
- Liquid insert plates
- Vac-norm external vacuum kits
- Vac-norm containers
- Smooth bags for vacuum
- packing
- Thermal labels for CG2 / RB printer
- RB desktop printer for SU vacuum packing machines
- Thermal transfer labels for RB printer

## SPECIFICATIONS

Pump capacity: 100 m³/h  
 Pump capacity (60 Hz): 120 m³/h  
 Bar length: 848 mm + 848 mm  
 Total loading: 2200 W  
 Vacuum pressure (maximum): 0.5 mbar

### Internal dimensions

- ✓ Width: 864 mm
- ✓ Depth: 603 mm
- ✓ Height: 215 mm

### External dimensions (W x D x H)

- ✓ Width: 960 mm
- ✓ Depth: 757 mm
- ✓ Height: 998 mm

Noise level (1m.): 75 dB(A)  
 Background noise: 32 dB(A)

### Crated dimensions

840 x 1060 x 1200 mm

## AVAILABLE MODELS

- 1140958 SU-810P LL 400/50-60/3N
- 1140960 SU-810P+ LL 400/50-60/3N
- 1140961 SU-810GP LL 400/50-60/3N
- 1140963 SU-810GP+ LL 400/50-60/3N
- 1140988 SU-810P LL 208-240/60/3
- 1140990 SU-810P+ LL 208-240/60/3
- 1140991 SU-810GP LL 208-240/60/3
- 1140993 SU-810GP+ LL 208-240/60/3

\* Ask for special versions availability



product sheet  
updated 23/05/2024



# VACUUM SEALER SU-810LL

Floorstanding unit. 100m<sup>3</sup>/h. 848+848 mm.



FOOD PRESERVATION AND SOUS-VIDE  
VACUUM PACKING MACHINES • SENSOR ULTRA LINE

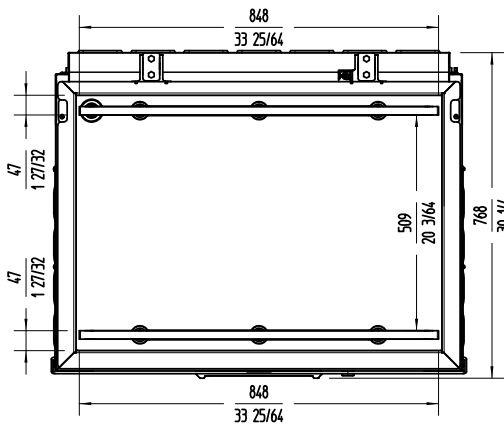
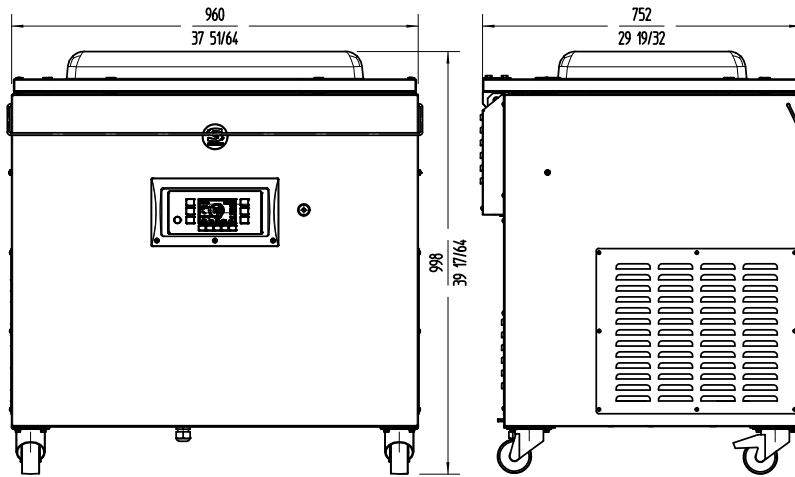

**sammic** | [www.sammic.com](http://www.sammic.com)  
Food Service Equipment Manufacturer

Polígono Basarte, 1. phone +34 943 15 72 36  
20720 Azkoitia, Spain sales@sammic.com



Project	Date
Item	Qty
Approved	

product sheet  
updated 23/05/2024