



VACUUM SEALER SU-6100

Double chamber vacuum packing machine. 100m³/h.



FOOD PRESERVATION AND SOUS-VIDE
VACUUM PACKING MACHINES • SENSOR ULTRA LINE

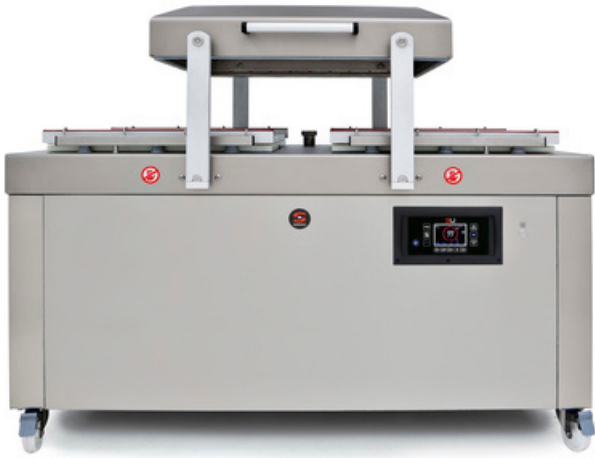

SALES DESCRIPTION

High performance model with tilting cover, double chamber and 4 x 662 mm. sealing bars.
100 m³/h Busch vacuum pump.
Vacuum controlled by sensor.

- ✓ Powered by Busch.
- ✓ Vacuum controlled by sensor.
- ✓ Vacuum PLUS.
- ✓ LCD colour screen: all information at a glance.
- ✓ Backlit touch keyboard.
- ✓ Programmable: 25-programme memory. Blocking option.
- ✓ "Pause" button.
- ✓ Phased vacuum programme.
- ✓ Detection of the evaporation of liquids.
- ✓ Double seal.
- ✓ Cordless sealing bar.
- ✓ Progressive decompression.
- ✓ Stainless steel body and chambers.
- ✓ Tilting cover made of thick, robust stainless steel.
- ✓ Dry-oil programme for drying the pump.
- ✓ Working hours counter for oil changes.
- ✓ Safety system with protection against vacuum failure.

INCLUDES

- ✓ Busch pump.
- ✓ Sensor controls.
- ✓ Programmable.
- ✓ Vacuum plus: up to 10 seconds of extra vacuum pull.
- ✓ Soft air function.
- ✓ Pause function.
- ✓ Liquid detection system.
- ✓ Dry oil cycle.
- ✓ NSF approved.
- ✓ 4 filling plates.

OPTIONAL

- Inert gas.
- Printer.
- Wireless connectivity.
- Vacuum packing bags.
- Bag cutting kit.
- Support for liquid packaging.
- Additional filling plates.

ACCESSORIES

- Bag cutting kits
- Filling plates
- Liquid insert plates
- Smooth bags for vacuum packing
- Thermal labels for CG2 / RB printer
- RB desktop printer for SU vacuum packing machines
- Thermal transfer labels for RB printer

SPECIFICATIONS

Pump capacity: 100 m³/h
Pump capacity (60 Hz): 120 m³/h
Bar length: 662 mm + 662 mm
Total loading: 2200 W
Vacuum pressure (maximum): 0.5 mbar

Internal dimensions

- ✓ Width: 662 mm
- ✓ Depth: 656 mm
- ✓ Height: 205 mm

External dimensions (W x D x H)

- ✓ Width: 1640 mm
- ✓ Depth: 874 mm
- ✓ Height: 1370 mm

Noise level (1m.): 75 dB(A)
Background noise: 32 dB(A)

Crated dimensions

980 x 1720 x 1280 mm

AVAILABLE MODELS

1141049	Vacuum packing machine SU-6100P 220/60/3 -C-
1141033	SU-6100P 400/50-60/3N
1141035	SU-6100P+ 400/50-60/3N
1141036	SU-6100GP 400/50-60/3N
1141038	SU-6100GP+ 400/50-60/3N
1141043	SU-6100P 220/60/3
1141045	SU-6100P+ 220/60/3
1141046	SU-6100GP 220/60/3
1141048	SU-6100GP+ 220/60/3
1141072	SU-6100GP+ 208-240/60/3 USA
1141069	SU-6100P 208-240/60/3 USA
1141073	SU-6100P+ 400/50/3N BE
1141074	SU-6100GP+ 400/50/3N BE

* Ask for special versions availability



product sheet
updated 15/03/2024



VACUUM SEALER SU-6100

Double chamber vacuum packing machine. 100m³/h.



FOOD PRESERVATION AND SOUS-VIDE
VACUUM PACKING MACHINES · SENSOR ULTRA LINE

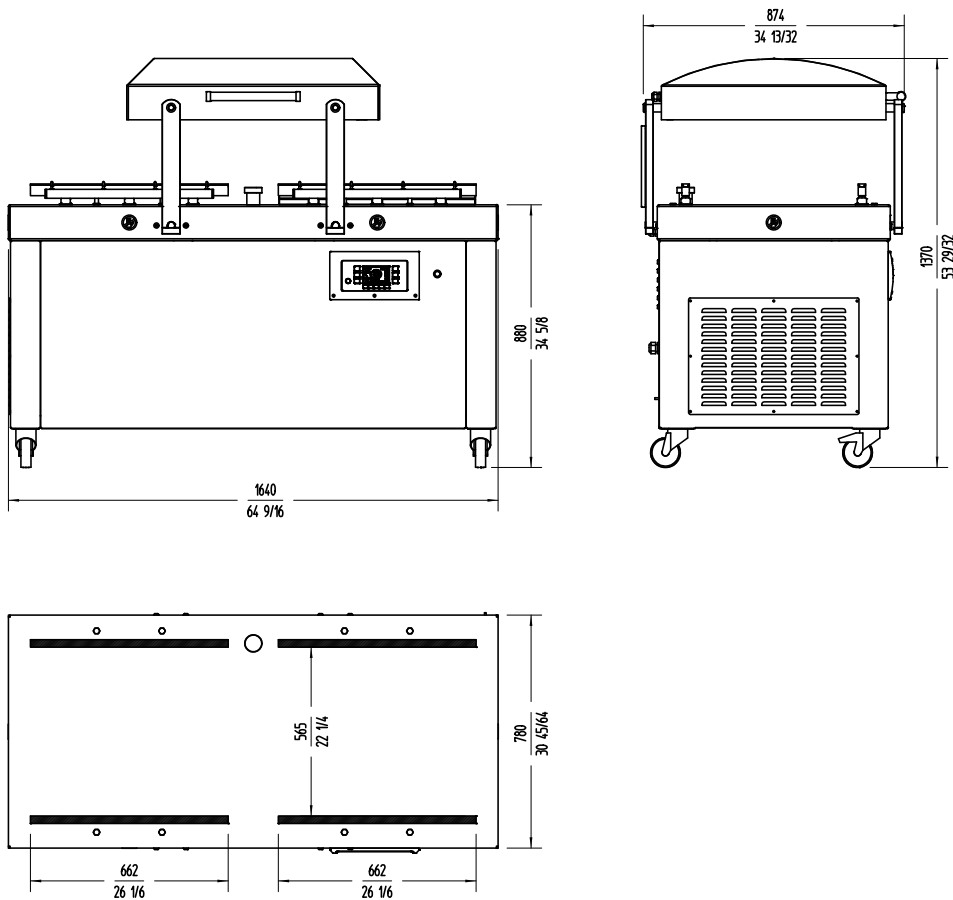

sammic | www.sammic.com
Food Service Equipment Manufacturer
 Polígono Basarte, 1. phone +34 943 15 72 36
 20720 Azkoitia, Spain sales@sammic.com



Project	Date
Item	Qty
Approved	

product sheet
updated 15/03/2024