



# POTATO PEELER PI-20

20 kg / 44 lb load per cycle.



Total loading: 550 W

### External dimensions (W x D x H)

- ✓ Width: 433 mm
- ✓ Depth: 635 mm
- ✓ Height: 786 mm

### External dimensions with stand

- ✓ Width with stand: 433 mm
- ✓ Depth with stand: 638 mm
- ✓ Height with stand: 1155 mm

**Net weight:** 38/36 kg

**Noise level (1m.):** 70 dB(A)

**Background noise:** 32 dB(A)

**Water Intake:** 12 mm

**Drain diameter:** 80 mm

### Crated dimensions

670 x 470 x 930 mm

## AVAILABLE MODELS

1000618 Potato peeler PI-20 120/60/1

1000660 Potato peeler PI-20 230-400/50/3N

1000661 Potato peeler PI-20 230/50/1

1000662 Potato peeler PI-20 220-380/60/3N

1000663 Potato peeler PI-20 220/60/1

1000993

1000994

\* Ask for special versions availability

## SALES DESCRIPTION

Stainless steel construction commercial potato peeler. Also suitable to peel carrots and other similar products. 0-6 min timer. Removable turntable for easy cleaning.

High capacity and production owing to lateral stirrers covered with silicon carbide abrasive (approved by NSF). Aluminium base plate lined with silicon carbide abrasive (approved by NSF). Construction in stainless steel.

- ✓ Auto-drag of waste to the drain.
- ✓ Energy efficiency owing to engine optimisation.
- ✓ Lifiable transparent cover, complete with locking and safety device.
- ✓ Aluminium door with hermetic seal and safety device.
- ✓ Waterproof control board (IP65): Improved reliability against moisture and water splash.
- ✓ Water inlet system with non-return air break.
- ✓ Auxiliary contact for external electric valve.
- ✓ 0-6min timer and possibility of continuous operation.
- ✓ Removable plate for easy cleaning.

## OPTIONAL

- Stainless steel floor stand complete with filter with no-foam feature.

## ACCESSORIES

- Stands for potato peelers
- Filters for potato peelers M / PI / PES

## SPECIFICATIONS

Hourly production: 400 kg / 480 kg  
Capacity per load: 20 kg  
Timer (min-max): 0' - 6'



DYNAMIC PREPARATION  
COMMERCIAL POTATO PEELERS

product sheet  
updated 22/07/2024



# POTATO PEELER PI-20

20 kg / 44 lb load per cycle.



DYNAMIC PREPARATION  
COMMERCIAL POTATO PEELERS

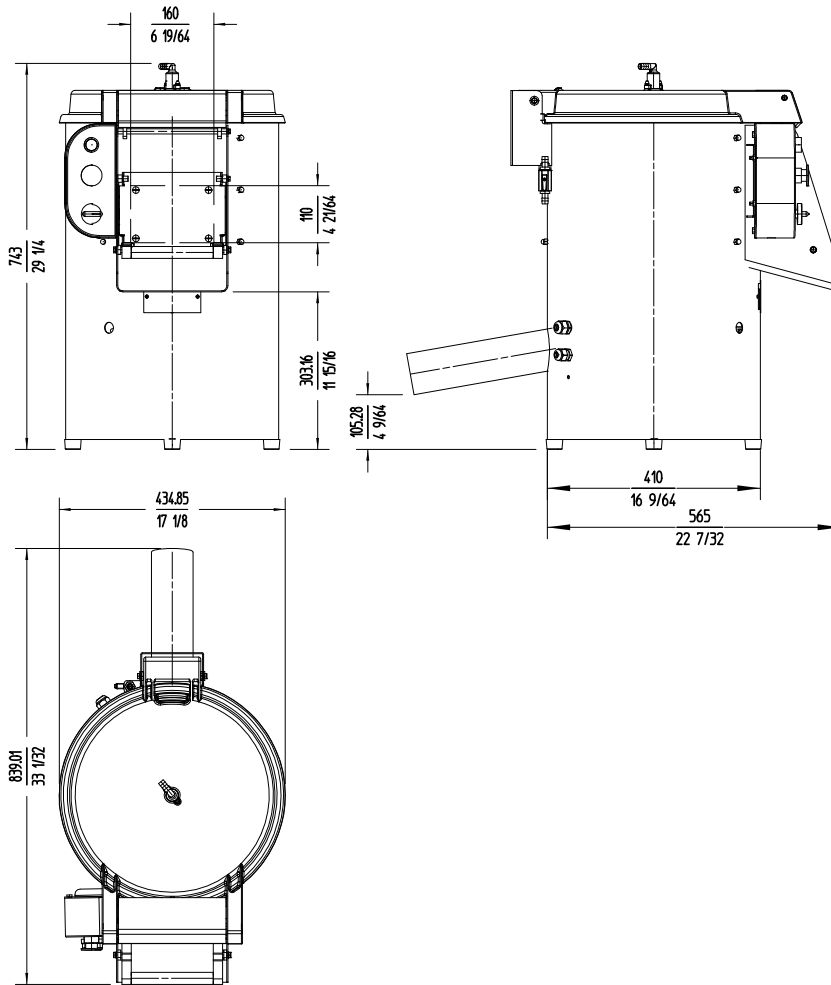

**sammic** | www.sammic.com  
Food Service Equipment Manufacturer

Polígono Basarte, 1. phone +34 943 15 72 36  
20720 Azkoitia, Spain sales@sammic.com



|         |      |
|---------|------|
| Project | Date |
| Item    | Qty  |

Approved

product sheet  
updated 22/07/2024